



Service Manual

A series modular air-cooled chiller (heat pump)

T1/ R410A /50Hz

T1/ R32 /50Hz



Contents

1 Product information	3
1.1 Introduction	3
1.1.1 Lineup	3
1.1.2 Nomenclature	3
1.1.3 Product features	4
1.1.4 Nominal operating conditions	4
1.1.5 Operation range	5
1.2 Performance correction curves	5
1.3 Working principle	6
1.4 Technical parameters	10
1.4.1 Electrical parameters	10
1.4.2 Performance parameters	11
1.4.3 Scope of supply	13
2 Unit control	15
2.1 Schematic diagram	15
2.2 Operation flowchart	17
2.2.1 Cooling	17
2.2.2 Heating	18
2.3 Key control logics	19
2.3.1 Cooling control	19
2.3.2 Heating control	19
2.3.3 Control to the compressor	20
2.3.4 Control to the fan	20
2.3.5 Control to the 4-way valve	20
2.3.6 Control to the water pump	20
2.3.7 Control to the electric expansion valve	20
2.3.8 Protection	20
2.4 Introduction to controller	21
2.5 Smart management system	21
2.5.1 Long-distance monitoring/BMS interface	21

2.5.2	Network of the long-distance monitoring system.....	21
2.5.3	Hardware	22
2.5.4	Model selection instructions	23
3	Unit installation	26
3.1	Installation flowchart	26
3.2	Preparations before installation	27
3.2.1	Precautions for installation.....	27
3.2.2	Importance of installation	28
3.3	Installation instructions	29
3.3.1	Outline dimensions	29
3.3.2	Precautions for installation.....	33
3.3.3	Installation environment.....	33
3.3.4	Installation and service space.....	33
3.3.5	Installation foundation	34
3.3.6	Handling and lifting	34
3.3.7	Placement of the main unit.....	35
3.4	Piping and insulation.....	35
3.4.1	Installation of the water system.....	35
3.4.2	Requirements on piping	37
3.4.3	Installation of the expansion tank.....	39
3.4.4	Installation of condensate pipes.....	40
3.5	Electrical connection	42
3.5.1	Safety precautions	42
3.5.2	External connection	42
3.5.3	Specification of power supply.....	47
3.5.4	Wiring of the electric control cabinet	47
3.5.5	Field wiring.....	49
3.5.6	Networking and wiring between units.....	51
3.5.7	Jumpers	53
4	Test operation, troubleshooting and maintenance	55
4.1	Commissioning	55

4.1.1	Flowchart of commissioning	55
4.1.2	Safety precautions for commissioning.....	55
4.1.3	Preparation before commissioning.....	55
4.1.4	Check before commissioning	55
4.1.5	Check for initial run	56
4.2	Troubleshooting	58
4.2.1	Diagnostics	58
4.2.2	Flow chart of troubleshooting.....	60
4.3	Power distribution	66
4.3.1	Power distribution logic	66
4.3.2	Introduction to main electric elements.....	66
4.3.3	Main board	67
4.4	Replacement of main parts	69
4.4.1	Brief introduction.....	69
4.4.2	Replacement instructions.....	70
4.5	Routine maintenance	91
4.5.1	Repairs to refrigerant leakage.....	91
4.5.2	Air removal.....	92
4.6	Exploded views and part lists.....	93
4.7	Maintenance	105
4.7.1	Requirements for maintenance	105
4.7.2	Freeze protection in winter.....	107

Product

SAFETY NOTICE

The following symbols are used in this document to alert the reader to potential of hazard.

 **WARNING** indicates a potentially hazardous situation which, if not avoided, could result in damage to the machine as well as death or serious injury.

 **CAUTION** identifies a hazard which could lead to minimal or moderate damage to the machine as well as death or serious injury.

 **BAN** indicates a potentially hazardous situation which, if not avoided, could result in death or serious injury.

 **COMPLIANCE** identifies a hazard which could lead death or serious injury as well as damage to the property.

PREFACE

Thank you for selecting Gree's A Series Inverter Modular Air-cooled Chiller (Heat Pump). Please read this instruction manual carefully before installing and using the product, we hereby instruct as below:

This Manual is applied to A Series Inverter Modular Air-cooled Chiller (Heat Pump), specifying operation safety requirements, basic principles and implementation approaches for construction fulfillment, construction debug, after-sale maintenance and repairs. All works must be performed in accordance with the relevant national (and local) safety requirements and User's Manual, which if not abided, could result in potential damage to the air conditioner, and even serious injury or death.

1 Product information

1.1 Introduction

1.1.1 Lineup

Model	Cooling capacity	Heating capacity	Power supply	Refrigerant	Appearance
	kW	kW			
LSQWRF35VM/NaA-M	32	36	380–415VAC 3Ph 50Hz	R410A	
LSQWRF60VM/NaA-M	60	65			
LSQWRF65VM/NaA-M	65	70			
LSQWRF35VM/NhA-M	32	35		R32	
LSQWRF60VM/NhA-M	60	65			
LSQWRF130VM/NhA-M	130	137			

1.1.2 Nomenclature

LS	QW	R	F	60	V	M	/	Na	A	-	M
1	2	3	4	5	6	7		8	9		10

No.	Code description	Options
1	Unit	LS: chiller
2	Compressor type	QW: hermetic scroll/rotary type
3	Unit function	Omit: cooling only
		R: heat pump
4	Cooling method of condenser	F: air-cooled
5	Rated cooling capacity	Rated cooling capacity = number (kW)
6	System type	Omit: fixed frequency, V: variable frequency
7	Assembly method	M: modular
8	Refrigerant type	Na: R410A, Nh: R32
9	Design code	A-Z alphabetic order
10	Power code	M: 380–415VAC 3Ph 50Hz

For instance, LSQWRF60VM/NaA-M indicates an inverter modular air-cooled chiller with a fully enclosed rotor-type compressor, featuring 60kW cooling capacity and using R410A refrigerant.

LSQWRF35VM/NhA-M indicates an inverter modular air-cooled chiller with a fully enclosed rotor-type compressor, featuring 35kW cooling capacity and using R32 refrigerant.

1.1.3 Product features

The all-inverter modular air-cooled chillers work outstandingly by virtue of their major features stated below.

(1) Excellent compatibility

The modular air-cooled chillers can be constructed of multiple single units with the same or different structure or capability (35kW, 60kW, 65kW, 130kW). For the 35kW unit, it has only one cooling system; for the 60kW, 65kW units, they are of two independent systems; for the 130 kW unit, there are four uniform independent systems. Up to 16 single units can be modularized, with cooling capacity ranging from 35kW to 1040kW.

(2) Comfort and energy saving

The inverter can quickly respond to load change and lead to decreased water temperature fluctuation and better comfort.

(3) Ultra quiet operation

The high-efficiency and low-noise fan blades and motor as well as the optimized air passage can greatly lower operation noise of the unit. Besides, the quiet mode can provide the user a ultra-quiet environment.

(4) Powerful self-protection

It is equipped with the top-end microcomputer control system which is capable of providing well-rounded protection and self-diagnosis.

(5) High reliability

It is constructed of well-designed refrigeration parts and well-designed system, structure and electric control, adequately guaranteeing reliable operation.

(6) Remote ON/OFF

The unit can be started or stopped by the ON/OFF key operation.

(7) Equilibrium running

It indicates each compressor will run alternately so as to extend their service life.

(8) Shiftwork of water pumps

Two water pumps can work alternately with equilibrium runtime so as to extend their service life and lower the maintenance difficulty.

1.1.4 Nominal operating conditions

Item	Water side		Air side	
	Water flow m ³ /(h·kW)	Outlet temperature (°C)	Dry bulb temperature (°C)	Wet bulb temperature (°C)
Cooling	0.172	7	35	-
Heat pump		45	7	6

1.1.5 Operation range

The unit should work within the specified operation range as shown in the table below:

Item	Water side		Air side
	Leaving water temperature (°C)	Water temperature difference (°C)	Ambient DB temperature (°C)
Cooling	5~20	2.5~6	-15~52
Heating	35~50	2.5~6	-20~40

Maximum and minimum entering water pressures

Item	Minimum entering water pressure	Maximum entering water pressure
Cooling	0.06MPa	1.6MPa
Heating		

1.2 Performance correction curves

Here are curves indicating the unit performances in cooling and heating states.

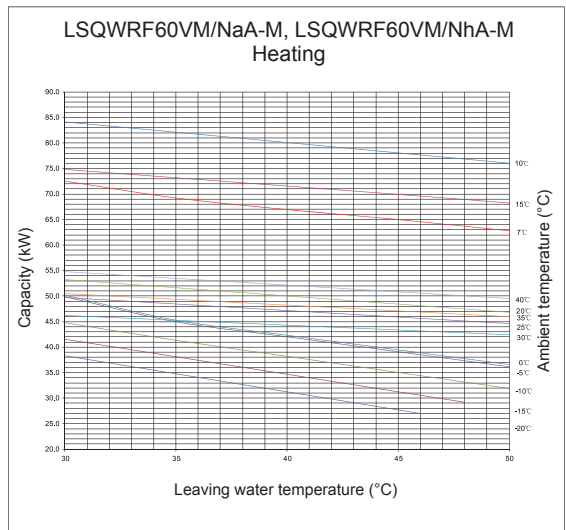
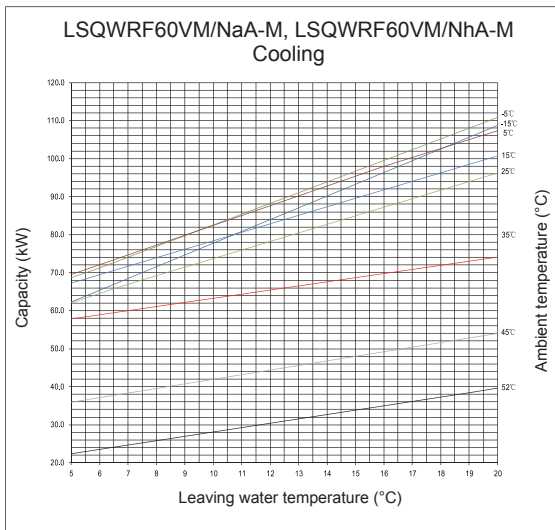
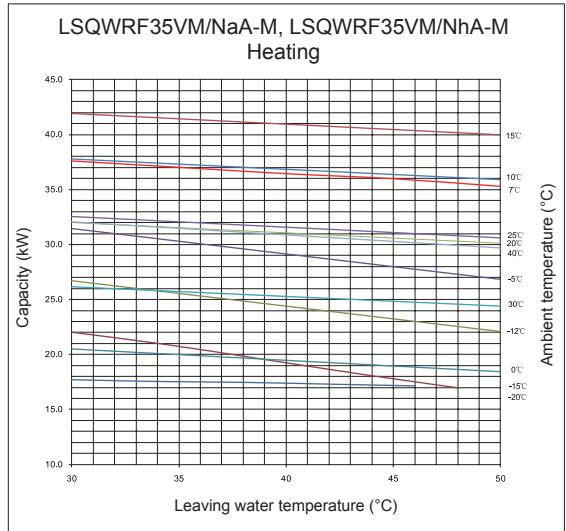
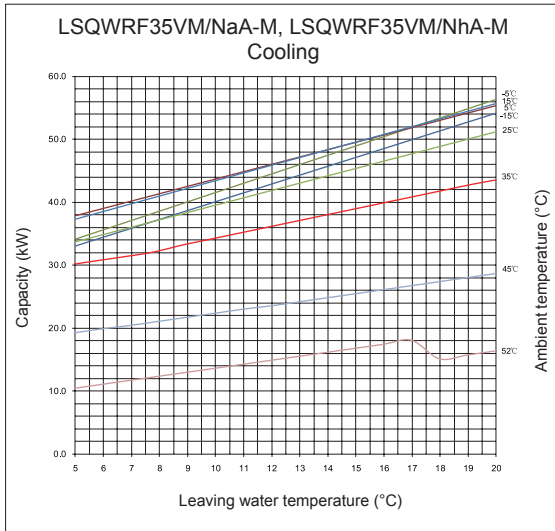

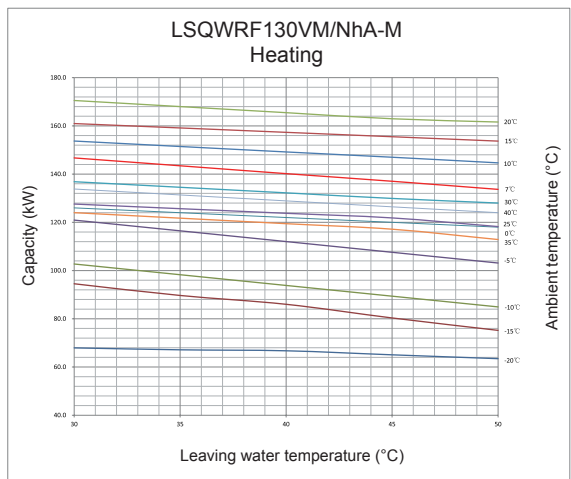
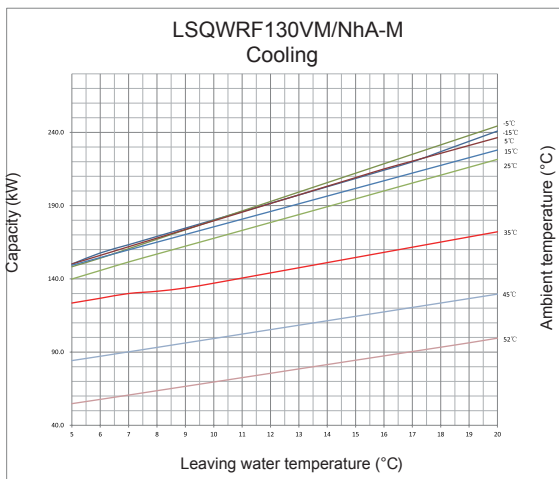
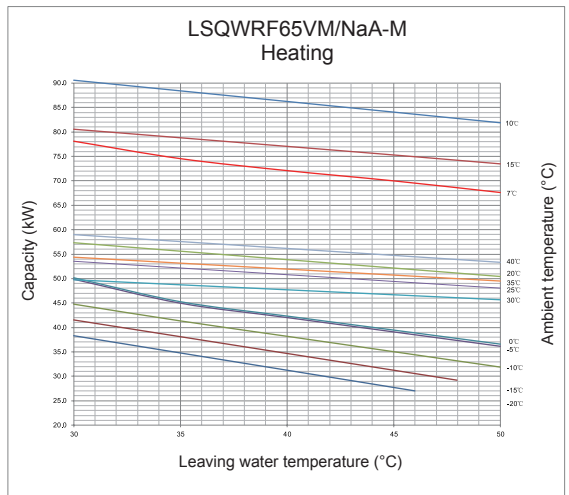
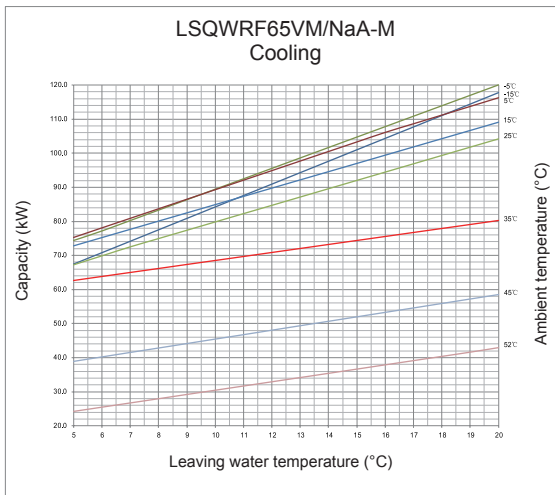

1.3 Working principle

Here are diagrams below to present the constituents and refrigerant flow of the system.

◆ R410A: LSQWRF35VM/NaA-M

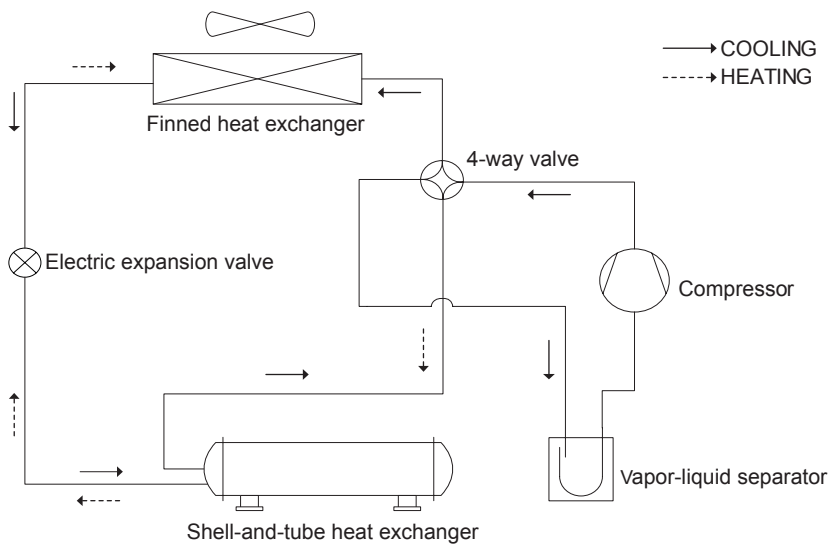

◆ R32: LSQWRF35VM/NhA-M

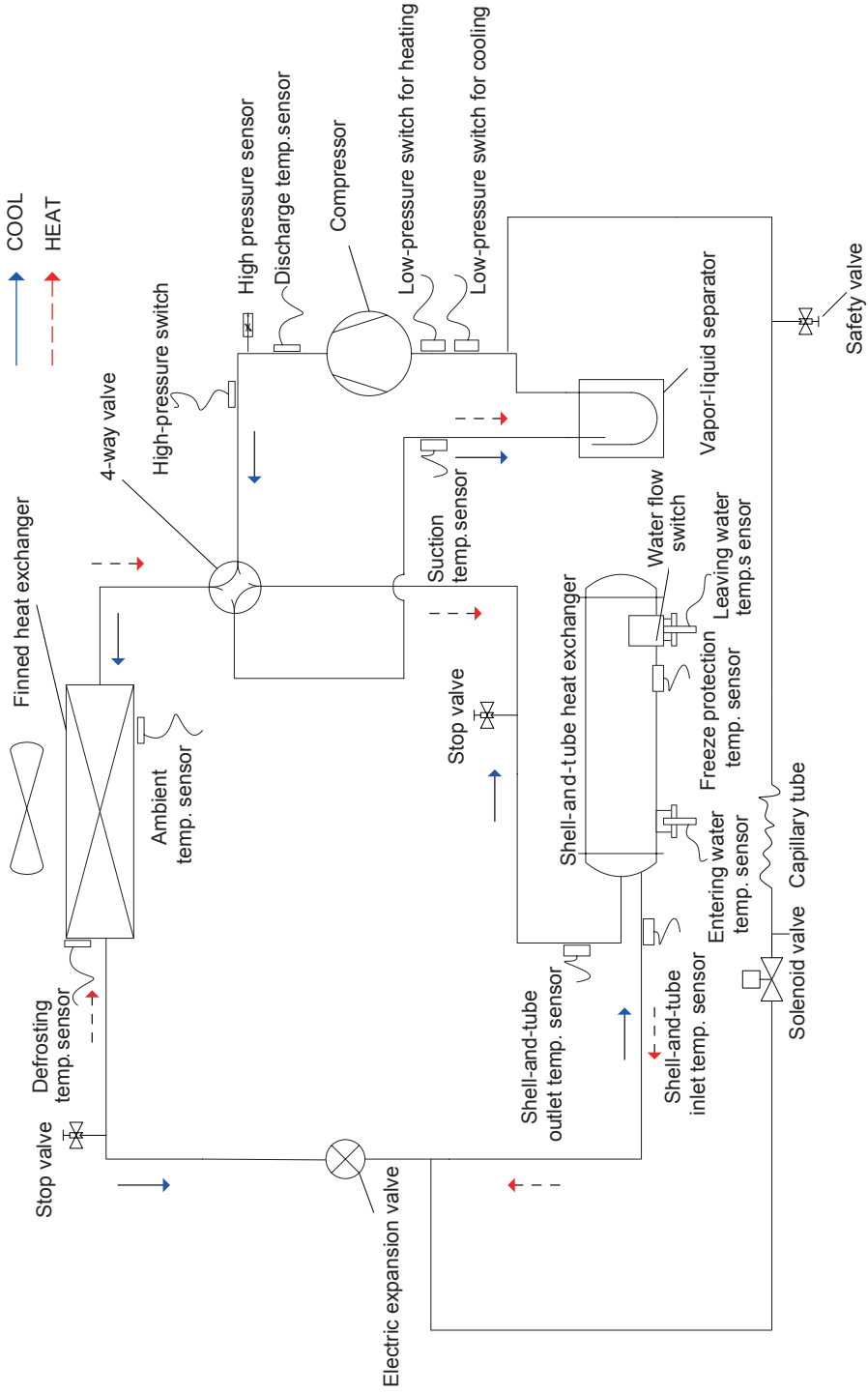

◆ R32: LSQWRF60VM/NhA-M

→ COOL
→ HEAT

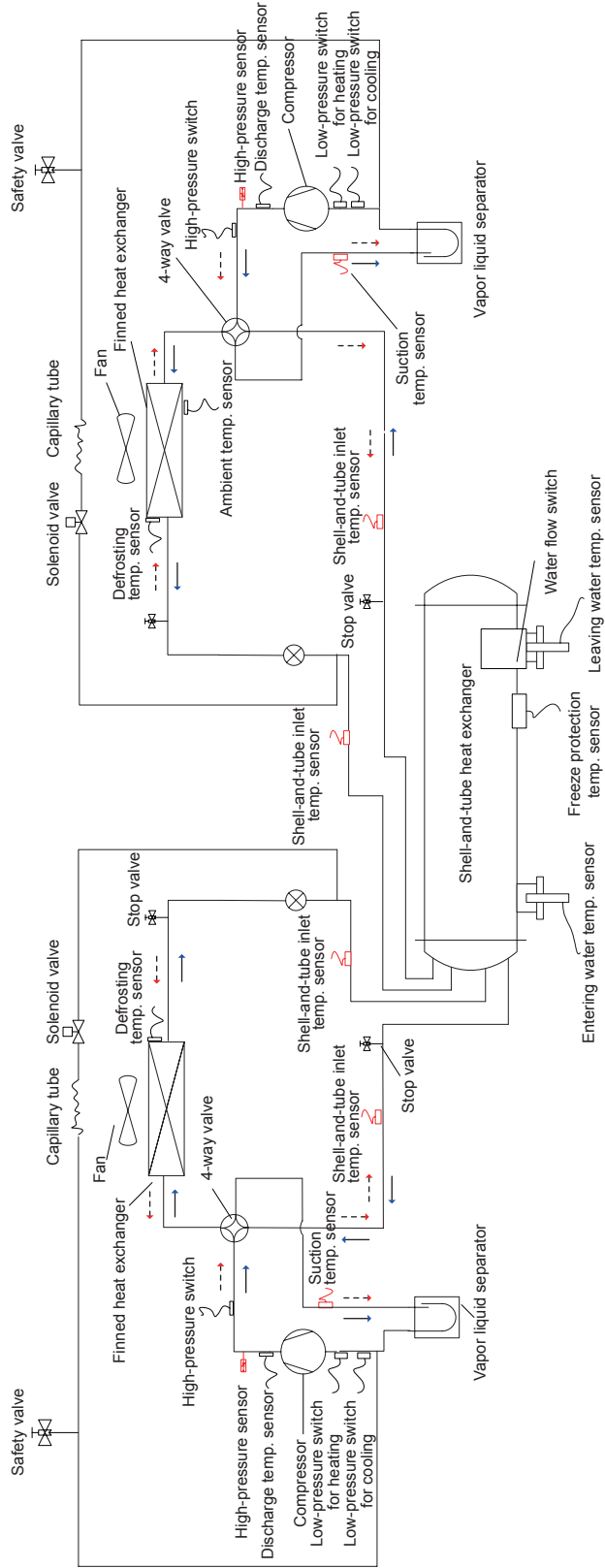

◆ R32: LSQWRF130VM/NhA-M

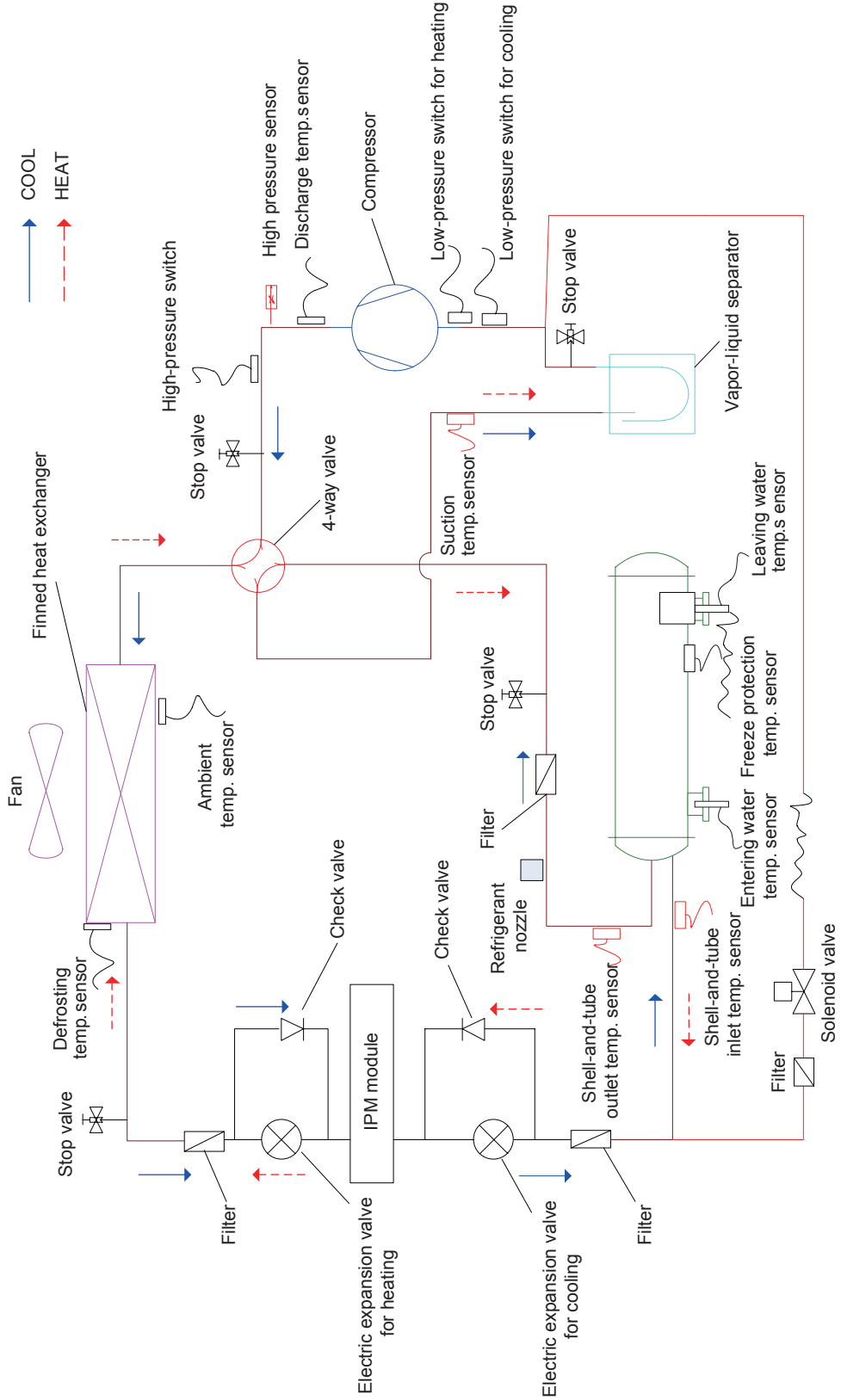

1.4 Technical parameters

1.4.1 Electrical parameters

Electrical data table

Model	Power supply	Compressor quantity	MRC (A)	NRC (A)	Fan quantity	NRC (A)
LSQWRF35VM/NaA-M	380V-415V AC 3Ph 50Hz	1	30	17.5	2	0.7
LSQWRF60VM/NaA-M	380V-415V AC 3Ph 50Hz	2	30	17.5	2	1.28
LSQWRF65VM/NaA-M	380V-415V AC 3Ph 50Hz	2	30	17.5	2	1.28
LSQWRF35VM/NhA-M	380V-415V AC 3Ph 50Hz	1	22	19.2	2	0.70
LSQWRF60VM/NhA-M	380V-415V AC 3Ph 50Hz	2	52	32.9	2	1.28
LSQWRF130VM/NhA-M	380V-415V AC 3Ph 50Hz	4	92	13.6±10%(60Hz)	4	1.28

Notes:

(a) MRC: maximum running current (A)

(b) NRC: nominal running current (A)

1.4.2 Performance parameters

Model		LSQWRF35VM/NaA-M	LSQWRF60VM/NaA-M	LSQWRF65VM/NaA-M	
Cooling capacity	kW	32	60	65	
Heating capacity	kW	36	65	70	
Rated cooling power	kW	12.4	21.9	24.8	
Rated heating power	kW	10.8	20.2	21.9	
Sound level	dB(A)	62	68	68	
Power supply		380–415V AC 3Ph 50Hz			
Operation control		The microcomputer implementing fully automatic control, displaying the operation state and giving an alarm			
Safety controls		High-pressure and low-pressure safety cut-out, high-discharge temperature cutout, freeze protection, overflow control, phase safety device, water flow safety control, pressure sensor cutout, temperature sensor cutout, four-way valve safety control, compressor overheating control			
Compressor	Type		Fully enclosed rotor-type compressor		
	Quantity		1	2	2
	Starting mode		With variable frequency		
	Water-side heat exchanger		High-efficiency shell and tube heat exchanger		
	Water flow volume	m ³ /h	5.5	10.32	11.18
	Water resistance	kPa	75	55	60
	The highest bearing pressure	MPa	4.6		
	Connection method		By external threads		
	Connection thread		G1 1/2 external thread	G2 external thread	G2 external thread
Air side	Air-side heat exchanger		High-efficiency finned coil heat exchanger		
	Rated power of fan	W	750×2	750×2	750×2
	Airflow volume	m ³ /h	1.26×10 ⁴	1.26×10 ⁴	1.26×10 ⁴
Outline dimension	Width	mm	1340	2200	2200
	Depth	mm	845	965	965
	Height	mm	1605	1675	1675
Net weight		mm	400	689	689
Operating weight		kg	400	758	758

Product

Model		LSQWRF35VM/NhA-M	LSQWRF60VM/NhA-M	LSQWRF130VM/NhA-M	
Cooling capacity	kW	32	60	130	
Heating capacity	kW	35	65	137	
Rated cooling power	kW	11.7	20.8	43.9	
Rated heating power	kW	10.6	19.9	41	
Sound level	dB(A)	62	68	69	
Power supply		380–415V AC 3Ph 50Hz			
Operation control		The microcomputer implementing fully automatic control, displaying the operation state and giving an alarm			
Safety controls		High-pressure and low-pressure safety cut-out, high-discharge temperature cut-out, freeze-up control, overflow control, phase safety device, water flow safety control, pressure sensor cutout, temperature sensor cutout, four-way valve safety control, compressor overheating control			
Compressor	Type	Fully enclosed rotor-type compressor			
	Quantity	1	2	4	
	Starting mode	With variable frequency			
	Water-side heat exchanger	High-efficiency shell and tube heat exchanger			
	Water flow volume	m ³ /h	5.5	10.32	22.36
	Water resistance	kPa	80	55	60
	The highest bearing pressure	MPa	4.6		
	Connection method	By external threads		By flanges	
	Connection thread	G1 1/4 external thread	G2 external thread	DN80	
Air side	Air-side heat exchanger	High-efficiency finned coil heat exchanger			
	Rated power of fan	W	750×2	750×2	750×4
	Airflow volume	m ³ /h	2×0.63×10 ⁴	2×1.2×10 ⁴	4×1.55×10 ⁴
Outline dimension	Width	mm	1340	2200	2305
	Depth	mm	845	965	1980
	Height	mm	1605	1675	2120
Net weight		mm	405	686	1286
Operating weight		kg	445	755	1413

1.4.3 Scope of supply

Item	Heat pump
Modules	S
Three-wire control lines (8m)	S
Accessories for the unit XE73-25/G	S (Additionally purchased)
Electric control cabinet	O
Auxiliary electric heater	O
Power lines	O
Control lines	O
Connecting hose	O
Thermometer	O
Pressure gauge	O

S= standard; O= field-supplied; P= optional

Unit Control

2 Unit control

2.1 Schematic diagram

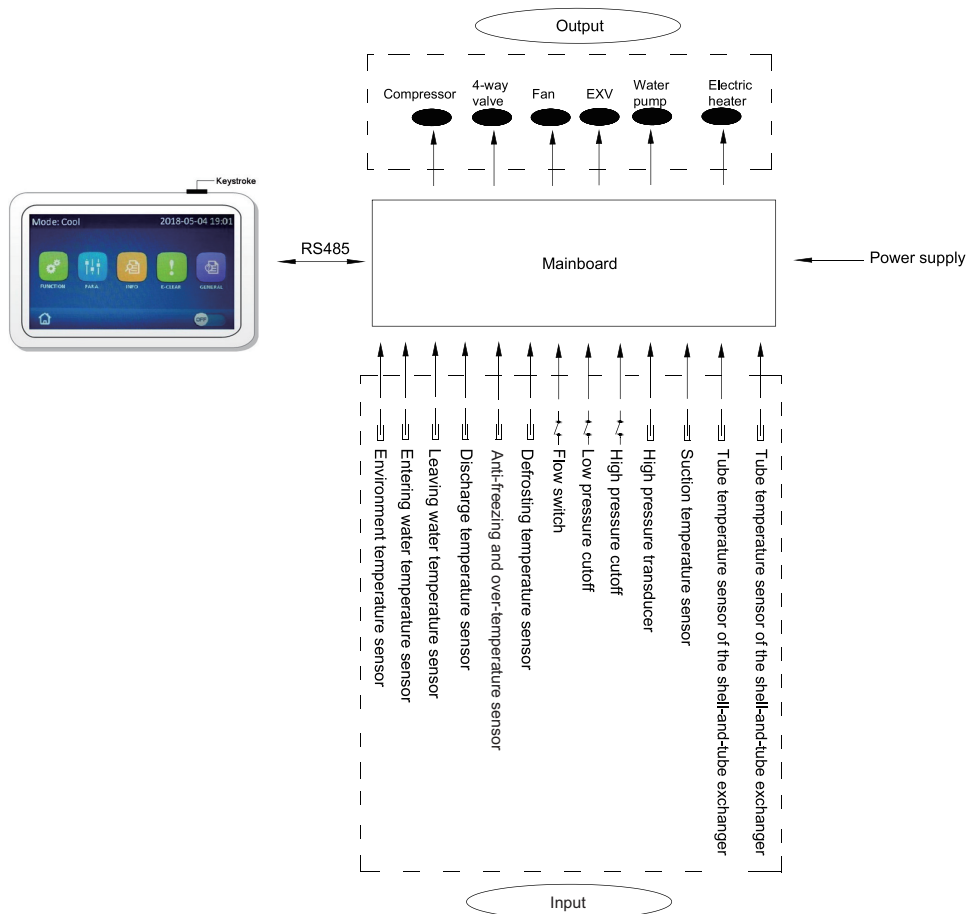

Description:

- (1) A water flow cutout is used to judge the water flow rate. When the flow rate is too low, it will trip off, and the control board will send this signal to the display and the water pump. Then, the display will tell there is an error, the water pump will stop and the unit will stop or will not start.
- (2) A high/low pressure cutout is used to judge the system pressure. When the system pressure is too high/low, it will trip off, and the control board will send this signal to the display. Then, the display will tell there is an error and the unit will stop or will not start.
- (3) An ambient temperature sensor is used to detect the temperature of the environment where the unit is which will determine whether to start or stop the fan and determine the steps of the electric expansion valve when initializing. When this sensor fails, the control board will detect and send this signal to the display. Then, the display will tell there is an error and the unit will stop or will not start.
- (4) A discharge temperature sensor is used to detect the discharge temperature. When the sensed temperature is too high or this sensor fails, the control board will detect and send this signal to the display. Then, the display will tell there is an error and the unit will stop or will not start.

- (5) An entering water temperature sensor is used to detect the temperature of the entering water which will determine whether to start or stop the compressor and the auxiliary electric heater. When this sensor fails, all compressors of the unit will stop.
- (6) Defrost temperature sensor is used to detect the liquid tube temperature of fins serving the condenser, which will determine whether to start the fan. When the sensed temperature is too high or this sensor fails, the control board will detect and send this signal to the display. Then, the display will tell there is an error and the unit will stop or will not start.
- (7) An anti-freezing and overheating prevention temperature sensor is used to detect the water temperature. When it fails, compressors and fans of the corresponding unit will stop.
- (8) A leaving water temperature sensor is used to detect the leaving water temperature. When this sensor fails, compressors and fans of the corresponding unit will stop.
- (9) An air temperature sensor on shell-and-tube heat exchanger is used to detect the air temperature. When this sensor fails, the compressor in a cooling state will have to be stopped and the display will tell there is an error. If the sensor fails in a heating state, only the display will tell an error.
- (10) An liquid temperature sensor on shell-and-tube heat exchanger is used to detect the liquid temperature. When this sensor fails, the compressor in a cooling state will have to be stopped and the display will tell there is an error. If the sensor fails in a heating state, only the display will tell an error.
- (11) A suction temperature sensor is used to detect the suction temperature. When this sensor fails, the compressor in a cooling state will have to be stopped and the display will tell there is an error. If the sensor fails in a heating state, only the display will tell an error.
- (12) High-pressure sensor is used to detect the discharge pressure. When the detected temperature is too high, control the compressor to regulate the frequency of discharge.

2.2 Operation flowchart

2.2.1 Cooling

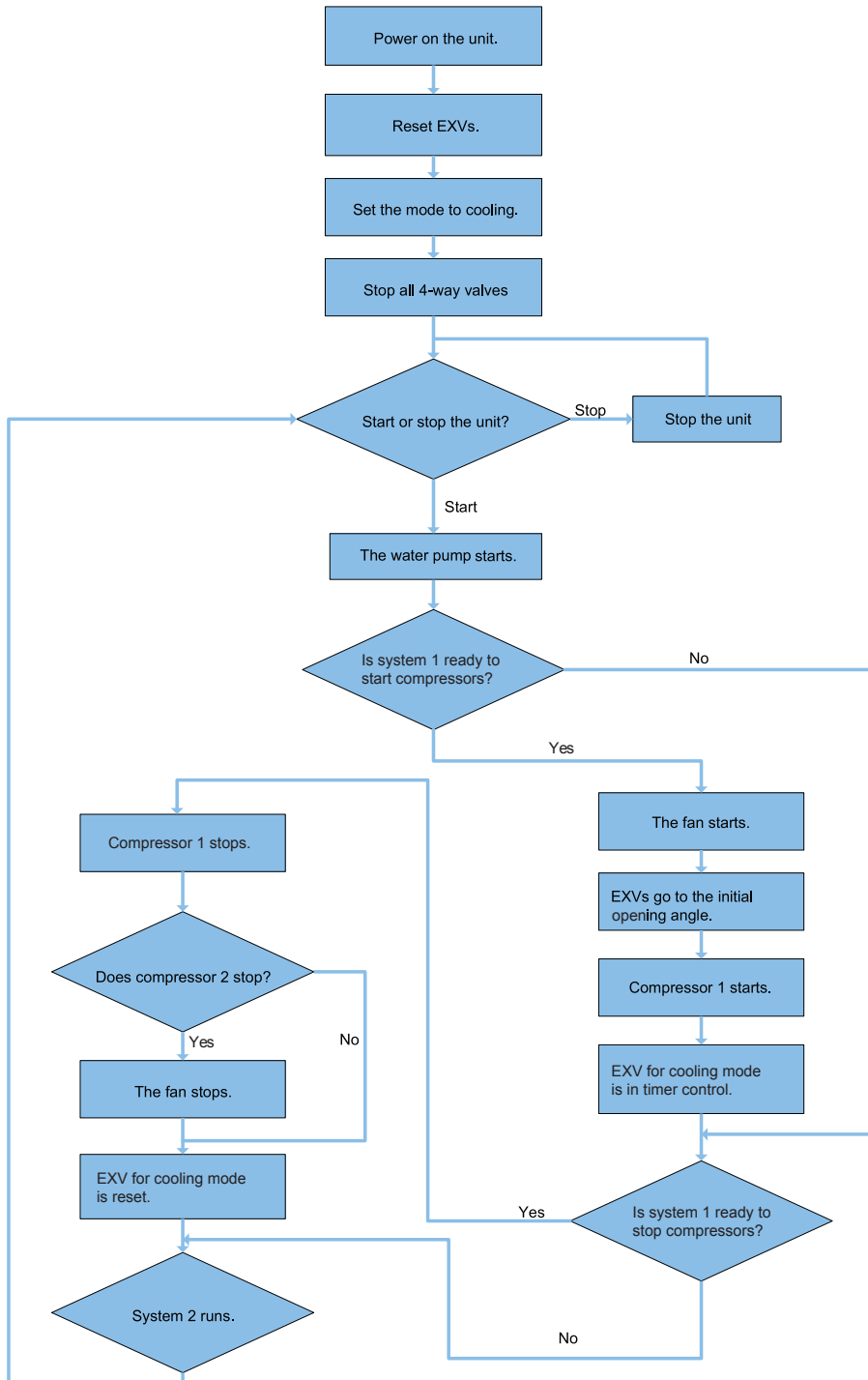

2.2.2 Heating

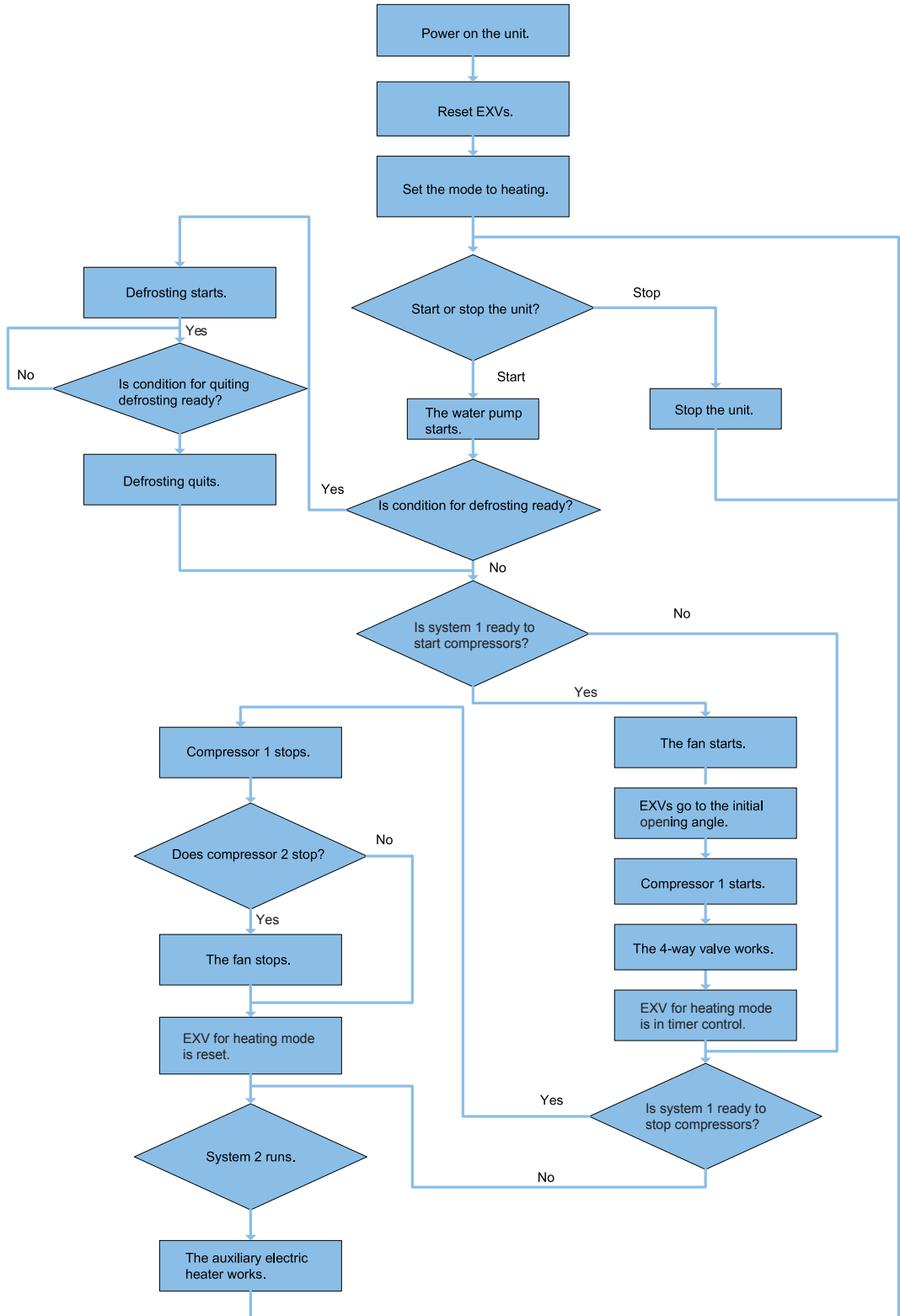

2.3 Key control logics

2.3.1 Cooling control

◆ Freeze protection

For each single unit, when the leaving water temperature is lower than the anti-freezing setpoint, freeze protection will work; when the leaving water temperature go higher than the normal value, freeze protection will be removed.

When the anti-freezing temperature and the leaving water temperature are between the anti-freezing setpoint and the normal value, the unit will keep the current operation status.

◆ Shutdown

Manual and timer shutdown: compressors, fans and then water pumps will stop.

Shutdown at the set temperature: compressors and fans will stop but water pumps will still be working.

Shutdown due to malfunction: compressors and fans will stop but water pumps will still be working.

2.3.2 Heating control

◆ Over-temperature protection for heating

For each single unit, when the leaving water temperature goes higher than the anti-over-temperature setpoint, over-temperature protection will work and the operation frequency of the compressor (or dual compressors) will be lowered until the leaving water temperature is lower than the setpoint. Stop compressors one by one if the operation frequency has been recorded the lowest and the leaving temperature remains above the setpoint for 1 minute.

With the leaving water temperature back to normal, over-temperature protection will be removed. If it occurs with a reduced frequency, the compressor should be controlled by the water temperatures for working as normal.

◆ Control to the auxiliary electric heater

When the control function of the auxiliary electric heater has been activated through the control panel, the unit is able control the auxiliary electric heater.

The auxiliary electric heater is able to work automatically as long as there is no fault of the flow switch and all entering and leaving water temperature sensors work normally.

When the control function of the auxiliary electric heater has been activated through the control panel, the auxiliary electric heater will not work any more.

When all entering and leaving water temperature sensors are faulty, the auxiliary electric heater will stop working.

When any flow switch fails, the auxiliary electric heater will stop working.

When over-temperature protection for heating works but the auxiliary electric heater is still required for operation, it will work continuously when its heating task is finished.

◆ Shutdown

Manual or timing shutdown: compressor stops firstly, and the auxiliary electric heater secondly, and then the fan and the water pump stop.

Shutdown upon the temperature set point: the compressor and the fan stop firstly, while the water pump keeps running.

Shutdown upon errors: the compressor stops firstly and the fan stops, while the water pump keeps running.

2.3.3 Control to the compressor

“First on, first off”/ “first off, first on” control indicates the numbered compressor which is started/ stopped firstly will then be stopped/started firstly.

2.3.4 Control to the fan

The fan will start when the unit is turned on and will stop when the compressor is turned off. During defrosting, the fan does not work but will back to working when defrosting exists.

2.3.5 Control to the 4–way valve

At the cooling mode, the 4–way valve will not work when the unit goes for defrosting or the unit is off. At the heating mode, the 4–way valve will work when the unit is turned on or defrosting quits.

2.3.6 Control to the water pump

When there is demand for any single unit, the water pump will start. When there is no demand for all water pumps, the water pump will stop.

2.3.7 Control to the electric expansion valve

The electric expansion valve will be initialized when the controller is powered on for the first time.

After the compressor has been started, the electric expansion valve starts to adjust its opening angle.

2.3.8 Protection

◆ Recoverable protection

The unit will stop when it receives no signal from the controller. Once there is any communication fault for any unit, all compressors of this unit will stop and then the water pump will follow.

◆ Irrecoverable protection

(1) Protection against high pressure for the compressor 1/2

When it is detected that the high pressure cutoff of the compressor 1/2 is tripped off, compressor 1/2 will stop immediately. If both compressors are closed, their fans will be delayed to stop. In this case, the control panel will display an alarm symbol, which should be cleared manually for resuming normal operation.

(2) Protection for the flow switch

When it is detected for some unit that the flow switch is opened, this unit will stop. When protection for the flow switch occurs for all unit, all compressors and water pumps will stop.

(3) Fault of communication

When a single unit does not receive any signal from the controller, this unit will stop automatically. For the unit with communication fault, when all its compressors stop and then the water pump will follow.

(4) Protection against phase loss/reversal

When there is phase loss or reversal for power supply, power for the main board will be cut off directly. In this case, there is nothing for the main board.

(5) Protection for abnormal 4–way valve

When it is detected that the entering water temperature is 4°C higher than the leaving water temperature and the leaving water temperature continuously goes down, the control panel will display this fault.

2.4 Introduction to controller

Please refer to the owner's manual of the controller before use.

2.5 Smart management system

2.5.1 Long-distance monitoring/BMS interface

This long-distance monitoring system allows users through a computer to remotely monitor up to 255 variable-frequency modular-type chillers, including turning on/off the units, setting parameters, giving alarms for malfunctions, which is an efficient tool for management of intelligent air conditioning systems for modern buildings.

2.5.2 Network of the long-distance monitoring system

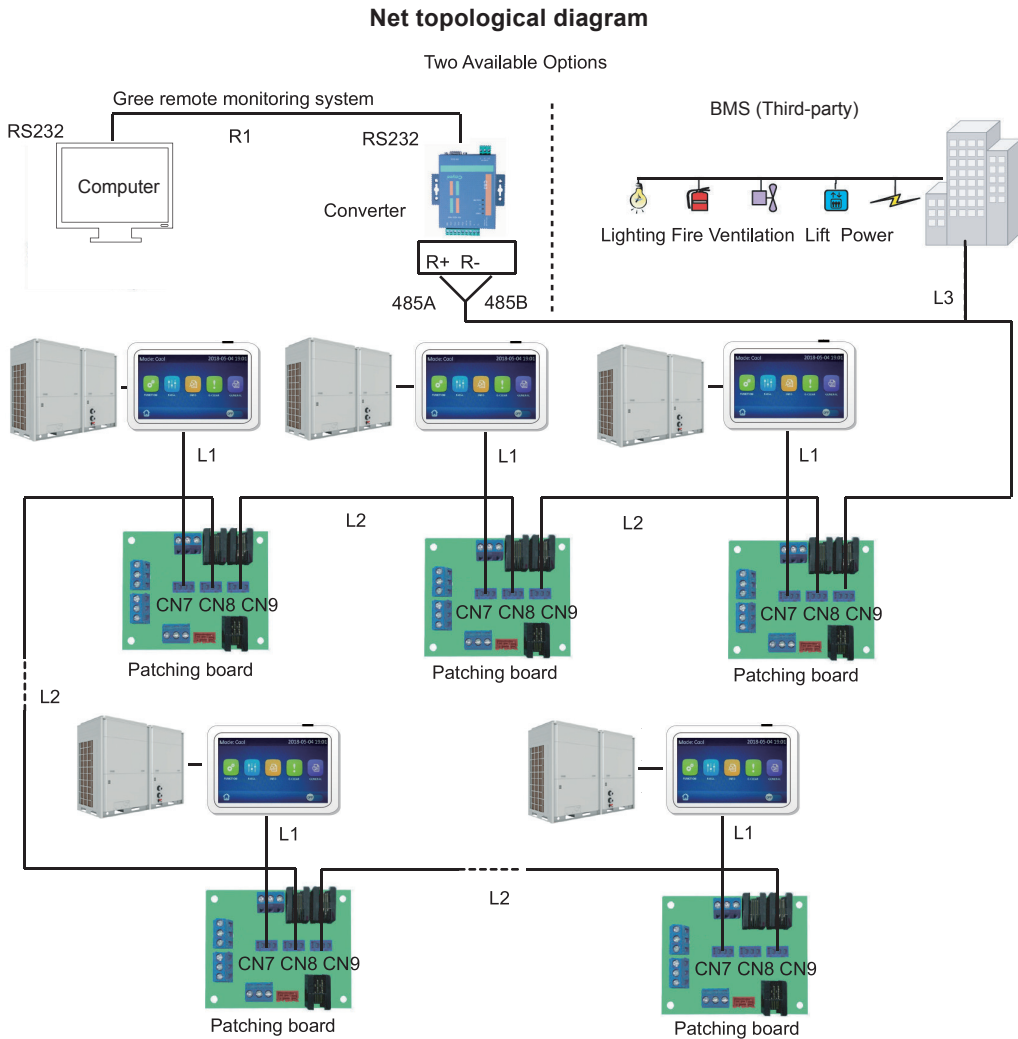

Note: the system as shown in the figure above consists of 1~16 single units depending on the actual demand of the project.

From the topological diagram above, the long-distance monitoring system consists of 3 parts:

The first part is the BMS and the converter used to convert RS232 signals from the BMS into RS485 signals of the long-distance monitoring network.(it is required only when RS232 is used for the BMS)The second part refers to the communication network including the communication lines and the connected hardware.

The second part refers to the communication network, that is, the communication lines and the connected hardware.

The third part is the patching board responsible for the data exchange between the air conditioning system and the monitoring PC. When there is only one unit, the patching board is not required and RS485 signal lines from BMS can be directly connected to the BMS port of the control panel. When there are multiple units, signal lines from BMS are required to connected to the BMS port through the patching board.

Communication lines

Line code	Description	Type
L1	Category– 5 twisted pairs, two four-wire connectors, one for the communication patching board, the other for the unit.	S
L2	Category-5 twisted pairs, two four-wire connectors	S
L3	Category-5 twisted pairs, one four-wire connector for the communication patching board, the other connector for RS232–485 photoelectric converter.	O
R1	DB9 serial port line	S

S=standard; O=field-supplied; P=optional

2.5.3 Hardware

Parts list

Name	Model	Code	Remarks	Type
Optoelectronic isolated repeater	RS485–W	LN02200010	A repeater is required every 800m communication distance or every 30 communication nodes (control panels).	P
Optoelectronic isolated converter	GD01	LN02200020	It is required when there is no remote monitoring kit but RS232 communication is used.	P
Remote monitoring kit	FG30-00/A(M)	MC200027	It is for remote monitoring other than BMS. Other main parts: monitoring software disc, optoelectronic isolated converter	S
Accessory XE73-25/G	XE73-25/G	NC20700050	It is required when several units forms a net work. It is intended to connect two or three communication lines. Other main parts: communication patching board (with fixed support), connection line	P

S=standard; O=field-supplied; P=optional

Notes:

- (a) When distance between the output of the BMS system or the output of the optoelectronic converter to CN4 of the display panel exceeds 800m, an optoelectronic repeater is required to reinforce signals.
- (b) The optoelectronic repeater is also required between the CN5 of the display panel and the main board for extending the communication distance.

2.5.4 Model selection instructions

- ◆ Rules for model selection

Supply scope

Item	Model	Type	Remarks
Computer	\	O	CPU: Pentium 4 or above
			Memory: 512M or above
			Hard disc: 30G or above
			Serial port: 1 at least
			Operation system: Windows XP/Windows 2003/Windows Vista/Windows 7
Remote monitoring kit	FG30-00/A(M)	S	It is for remote monitoring other than BMS. Other main parts: monitoring software disc, optoelectronic isolated converter
Communication patching board	ZTSJ0	P	It is required when several units forms a network.
Optoelectronic isolated converter	GD02	P	It is required when there is no remote monitoring kit but RS232 communication is used.
Optoelectronic isolated repeater	RS485-W	P	A repeater is required every 800m communication distance or every 30 communication nodes (control panels).
4-core (2-core) category 5 twisted pairs	\	O	Its length depends on the actual demand.

S=standard; O=field-supplied; P=optional

Selection of part quantity

Model	Communication patching board	Remote monitoring kit	Optoelectronic repeater
A series modular type chiller	One patching board for one unit	<ul style="list-style-type: none"> One set of remote monitoring kit FG30-00/A(M) is required; The remote monitoring kit is not required when the unit is directly Connected to the BMS system. 	A repeater is required every 800m communication distance or every 30 communication nodes (control panels).

◆ Examples of model selection

Example 1

This project consists of 3 LSQWRF60VM/NaA-M, one control panel and BMS. The maximum communication distance is within 800m. The BMS interface is RS232 and one converter is required.

Name	Code	Quantity
Air conditioning system	EL01500720	1 (3 LSQWRF60VM/NaA-M)
Optoelectronic converter	EN02200020	1

Example 2

This project consists of 7 groups LSQWRF60VM/NaA-M, six groups concluding 3 and the other concluding 1. Seven control panels are required. The communication distance is larger than 800m but be or less than 1600m. One repeater is required for somewhere the communication distance is over 800m. The BMS interface is RS485.

Name	Code	Quantity
A series variable-frequency modular type chiller	EL01500720	19 LSQWRF60VM/NaA-M
Accessory XE73-25/G	NC20700050	7
Patch board ZTSJ0	30118023	6
Optoelectronic repeater RS485-W	EN02200010	1

Example 3

This project consists of 35 air conditioning systems including 103 LSQWRF60VM/NaA-M units. Among them, there are 34 air conditioning systems which consists of 3 LSQWRF60VM/NaA-M. The remaining consists of 1 LSQWRF60M/NaA-M. Totally 35 control panels are required. A repeater is required for somewhere the communication distance is over 800m but less than 1600m and when the communication nodes (control panels) exceeds 35. The BMS interface is RS232. Besides, one converter is required.

Name	Code	Quantity
A series variable-frequency modular type chiller	EL01500720	103 LSQWRF60VM/NaA-M
Accessory XE73-25/G	NC20700050	35
Patch board ZTSJ0	30118023	34
Optoelectronic repeater RS485-W	EN02200010	2
Optoelectronic converter D02	EN02200020	1

Unit Installation

3 Unit installation

3.1 Installation flowchart

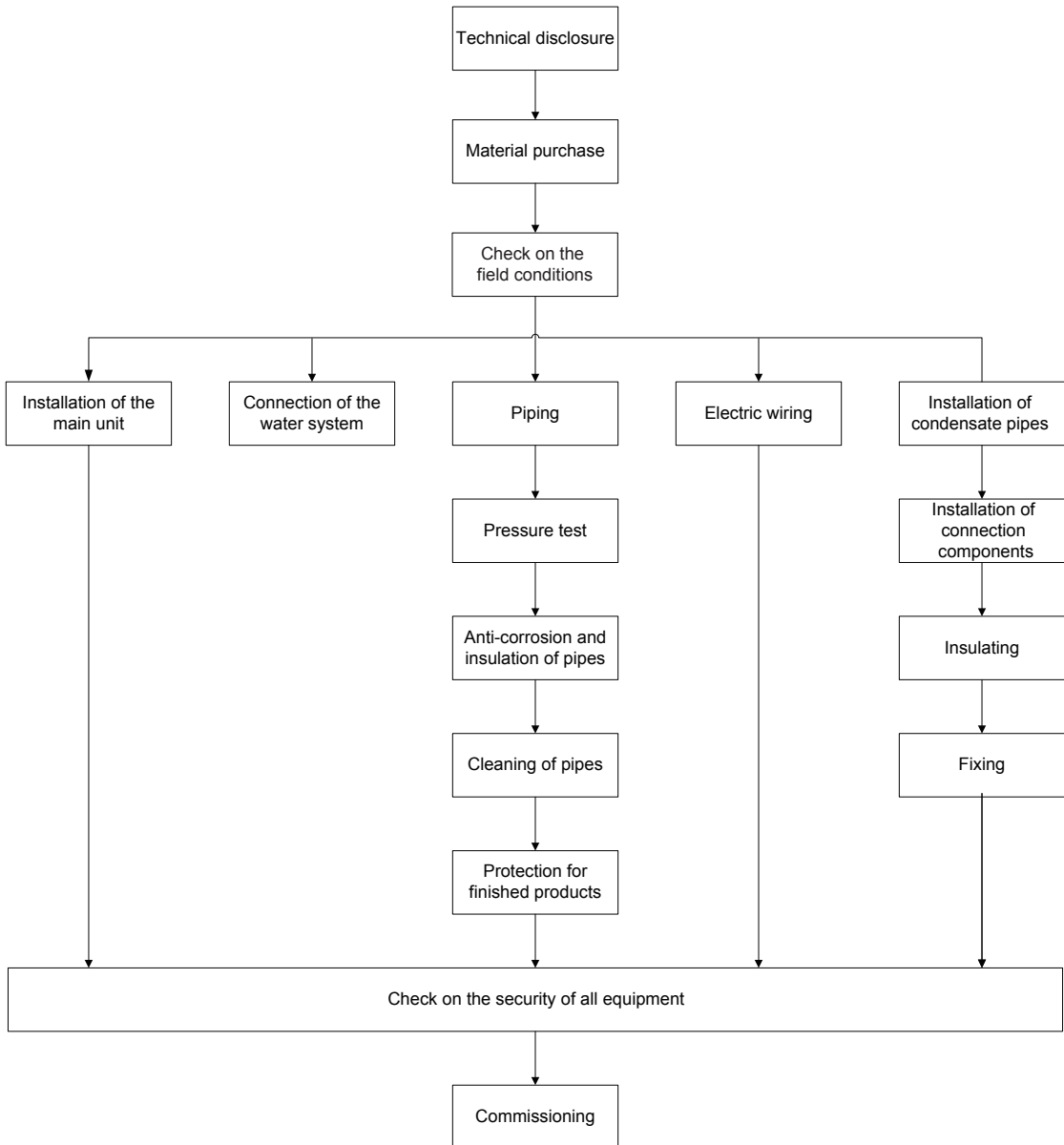

3.2 Preparations before installation

3.2.1 Precautions for installation

WARNING

- Installation should be performed by GREE appointed service personnel, or improper installation would lead to unusual operation, water leakage, electric shock or fire hazard.
- The unit should be installed on the foundation which is capable of supporting the unit, or the unit would fall off or even lead to personal injury.
- All electric installation should be done by electrician in accordance with local laws and regulations, as well as the User's Manual and this Service Manual. Besides, the special power lines should be used, as any improper line would lead to electric shock or fire hazard.
- All electric lines should be safe and secured reliably. Be sure the terminal board and electric lines will not be affected by any external force, or it would lead to fire hazard.
- The electric lines between the indoor and outdoor units should run properly to make the cover of the electric box secured tightly, or it would cause the terminal board overheated or cause electric shock or fire hazard.
- Cut off the power supply before touching any electric element.

CAUTION

- The unit should be grounded properly and the ground line is not allowed to connect with the gas line, water line, lightning rod or phone line.
- The breaker should be installed, or it would lead to electric shock.
- The drain pipe should be installed in accordance with the Installation, Startup and Maintenance Manual and this Service Manual to ensure free drainage, and the drain pipe should be insulated against condensation. Once the drain pipe is installed improperly, it would lead to water leak which then will damp the ceiling and furniture.
- Do not place the unit where there is oil fog, like kitchen, or the plastic would be aged, broken off or the polluted evaporator would lead to water leak and poor performance.
- Do not place the unit where there is corrosive gas (like sulfur dioxide), or the corroded copper tubes or welded joint would lead to refrigerant leakage.
- Do not place the unit where there is inflammable gas, carbon fiber, inflammable dust or volatile combustible, as they would lead to fire hazard.

CAUTION

- Always use safety outfits at the construction site.
- No smoking and no drunken operation are allowed at the construction site.
- Wear no gloves and tighten the cuff when operating the machinery and electrical equipment. Do not maintain it during operation.
- Use the abrasive-disk cutter and stand at the side of the rotating abrasive disk.
- Clean the opening when installing the riser pipe, and then cover it tightly. Do not throw down any material.
- The use of the electric and gas welders should be approved firstly. Once used, a fire extinguisher should be prepared and a service man should be there always. There should be no inflammable and explosive substances around the welding site.
- A platform should be set up when working high above the ground.

3.2.2 Importance of installation

See the table below for problems occurred frequently and impacts.

No.	Typical problems	Impact
1	Inadequate space for installation	It would lead to harder maintenance, poor ventilation, poor heat exchanging or even abnormal operation.
2	Improper piping of the water system	The unit would fail to run normally.
3	Improper cleaning for water piping	It would make foreign matters enter the water system, which then would lead to heavy scaling on the heat exchanger, cracked or leaked heat exchanger.
4	Mis-wiring of power lines	It would damage the electric element and lead to safety hazards.
5	Mis-wiring of communication lines	It would lead to abnormal communication.
6	Improper protection to the communication lines	The unit would fail to run with the communication fault.
7	Poor insulation for the chilled water lines	Missed, cracked, unqualified insulation and insulation with inadequate thickness would lead to poor heat exchanging.
8	Unqualified vibration reduction measures	Unqualified vibration reduction measures would lead to increased vibration and noise, or even abnormal operation.
9	No protective sleeve for the wall-thru water pipes	Water leak would be led to by friction between the wall-thru pipe and the wall.
10	Improper arrangement of equipment and pipes	Improper arrangement would make the machine room look messy.

Service providers should be qualified and know special requirements on installation for certain so as to guarantee installation quality. Otherwise, service personnel should be properly trained and licensed before servicing.

3.3 Installation instructions

3.3.1 Outline dimensions

(1) LSQWRF35VM/NaA-M

(unit:mm)

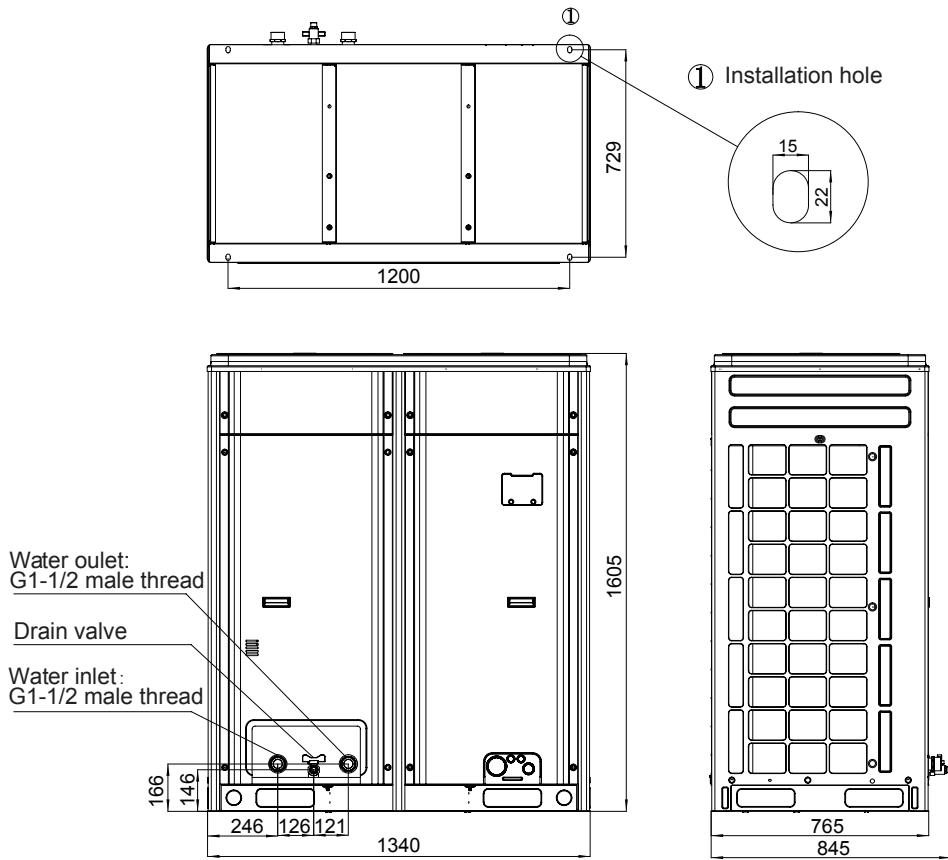

Unit Installation

(2) LSQWRF60VM/NaA-M, LSQWRF65VM/NaA-M

(unit:mm)

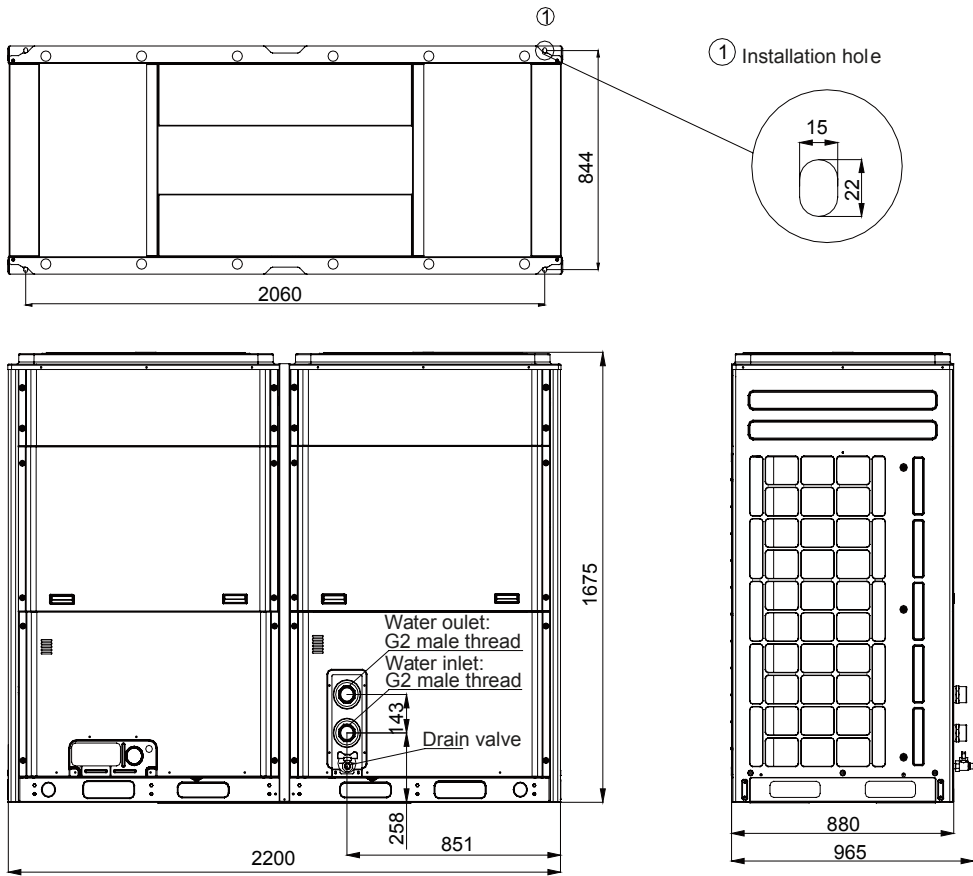

Unit Installation

(3) LSQWRF35VM/NhA-M

(unit: mm)

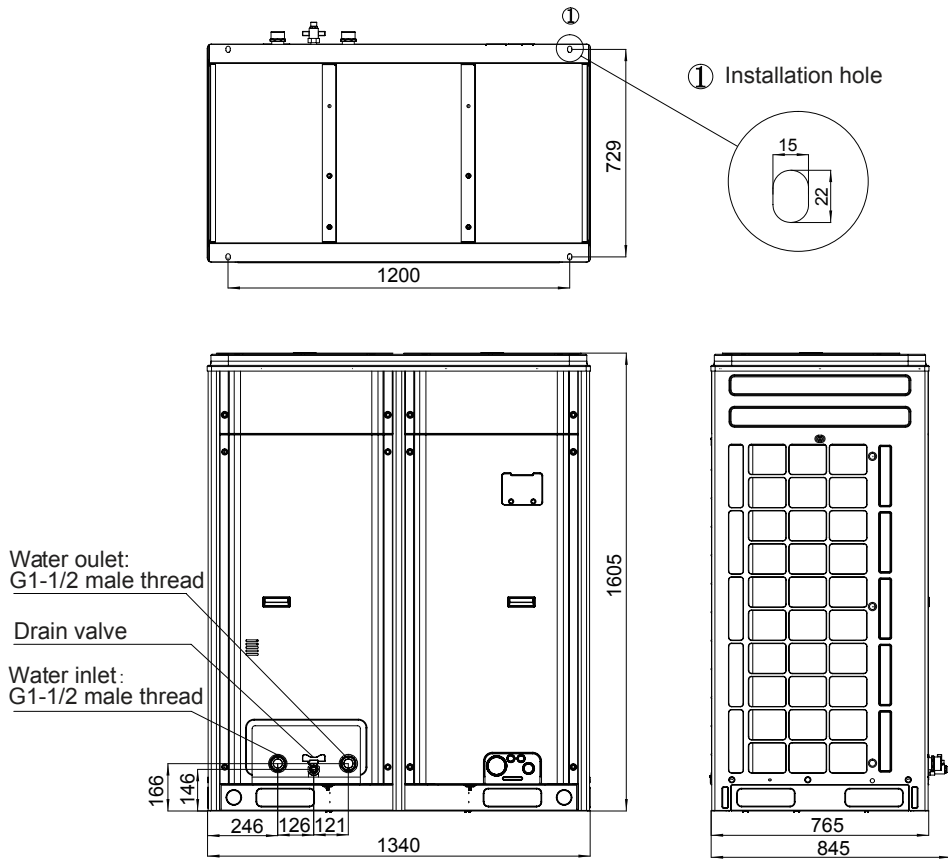

Unit Installation

(4) LSQWRF60VM/NhA-M

(unit: mm)

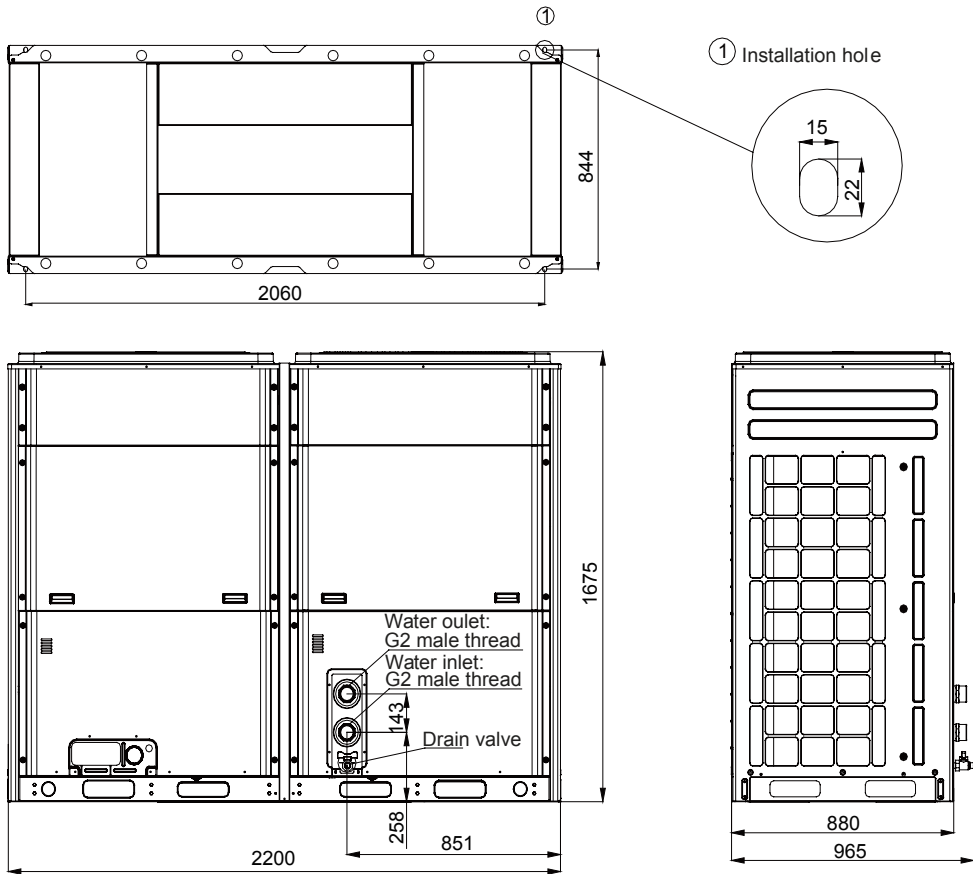

(5) LSQWRF130VM/NhA-M

(unit: mm)

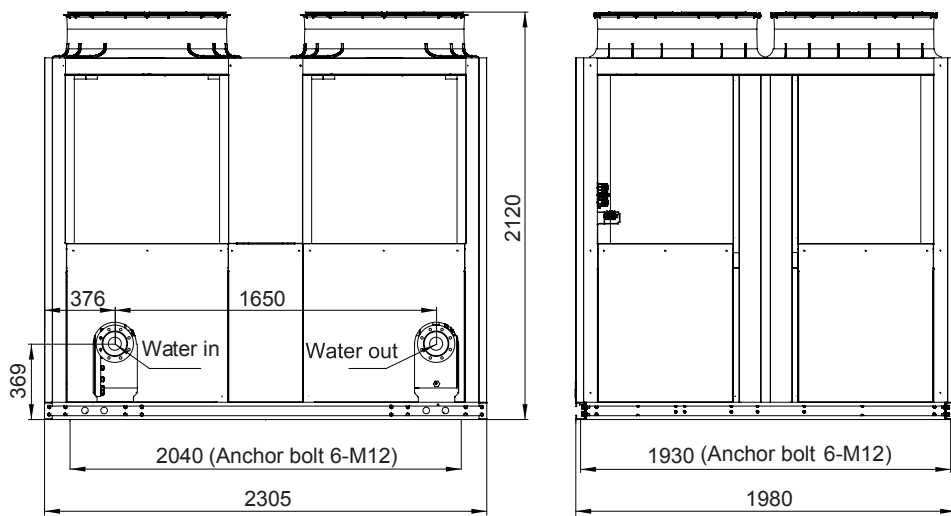

3.3.2 Precautions for installation

- (1) Pipelines and electric lines should be correctly connected.
- (2) Rubber pads and rubber flexible connectors should be used during installation for noise and vibration reduction.
- (3) Under subzero climate, when the heat pump runs for cooling, anti-freeze liquid is required.
- (4) Dedicated lugs should be used for lifting. During lifting, proper protection should be taken so as to avoid pipelines from being damaged.

3.3.3 Installation environment

- (1) The unit should not be installed within 25m of the residence; otherwise a sound insulating wall should be set up.
- (2) When the unit is to be installed at the roof, the foundation should be located at the heel posts. If the floor is quite thin, or there is vip rooms under the floor, the spring damper is required.
- (3) Fire, inflammably, corrosive gas and waste gas should be avoided around the unit. Also, the unit cannot be installed around the chimney and discharge fan.
- (4) Ventilation should be in good condition and no air flow would be trapped.

3.3.4 Installation and service space

The interval between each single unit should be larger than 0.5m so that there is enough space for entering air and maintenance. The distance between the unit and any barrier should be or larger than 1m so as to keep good ventilation around the unit.

If possible, a suncover can be set up 3m ahead of the unit.

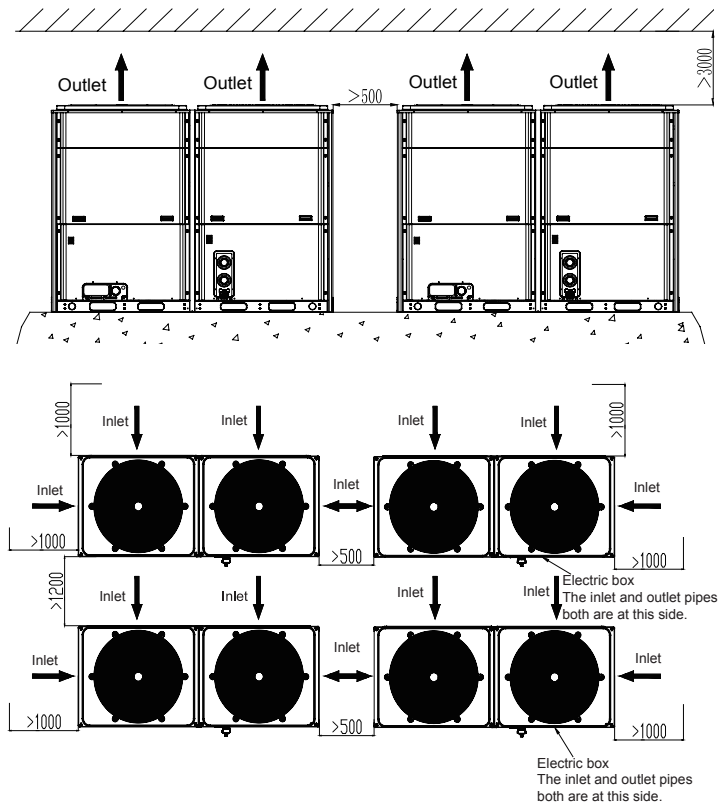

3.3.5 Installation foundation

- (1) The installation foundation should be designed by qualified designers.
- (2) The foundation should be made of cement or steel structure and be capable of supporting the weight of the unit. Additionally, the upper surface should be kept level. It would be better to keep drain grooves around the foundation.
- (3) The installation should be secure enough, and its surface should be smooth.

3.3.6 Handling and lifting

Handling and lifting of the main unit should be performed by a qualified installation team. During lifting, the main unit should be kept stable both horizontally and vertically.

Each unit will undergo a series of strict factory inspections and tests to guarantee the expected performance and quality. However, special attention should be paid during handling and shipping to prevent the control system and the piping system from being damaged.

The unit should be moved by the forklift or hoisting machine. During lifting, the canvas lifting or steel ropes in use should be of enough strength and go through the based and then bundled tightly. The unit should be lifted stably from four corners. Meanwhile, be sure there should be protective pads to prevent lifting ropes contacting with the unit. The inclination angle during lifting should be less than 15 degree. The unit should be moved softly and severe collision and forced drag are not allowed. Please do lifting as shown in the figure below for units with similar structure.

During hoisting, the length of the spreader should be longer than that of the unit.

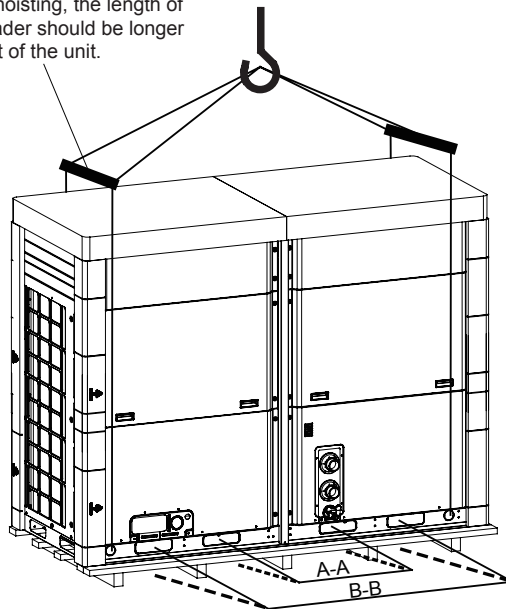

During transport by the forklift, the symmetric holes should be used at the A-A or B-B base of the unit itself, or at the wooden base.

3.3.7 Placement of the main unit

- (1) Place the unit on the foundation.
- (2) There should be no clearance between the foundation and the baseboard of the unit.
- (3) Lift the unit, put the rubber pad on the foundation and then place the unit on the rubber pad. After that, be sure the horizontal slope of the unit can't exceed 1/1000. If so, take an adjustment by stuffing spacers into the clearance between the foundation and the baseboard of the unit until the slope is satisfactory.



3.4 Piping and insulation

3.4.1 Installation of the water system

Considerations stated below shall be taken for the water system.

- (1) Each water inlet and outlet should be labeled properly to avoid misconnection.
- (2) A flexible connector should be used at the chilled water outlet to reduce vibration transmission.
- (3) A manometer, a thermometer and a gate valve shall be installed at the chilled water inlet /outlet. Moreover, a drain valve shall be installed at the outlet and an air release valve shall be installed at the inlet. At the highest point of the water system, another release valve shall be installed, while at the lowest point of the water system, another drain valve shall be installed to facilitate drainage.
- (4) The water inlet/outlet pipe should be tightly insulated to reduce heat loss and dewing. When pipes are exposed under 0°C, a electric heater shall be installed.
- (5) A filter shall be installed upstream of the water pump, otherwise there will be foreign matter entering the water system, then generating scale on the surface of heat exchangers.
- (6) Construct a temporary bypass around the unit to prevent drainage from flowing back to the interior of the unit.
- (7) Under ultra-low temperature in winter, shutdown at night will cause the evaporator and pipeline frozen up, so it is highly recommended to add alcohol and propanol mixture in chilled water. Do not cut off the power supply when the unit is turned off, otherwise the freeze protection does not work. Alternatively, cut off the power supply and drain the water system thoroughly.

(8) When the unit runs under the low load requirement, in order to avoid low load protection which would affect the service life of the unit, make sure the water capacity is more than 1/6 of total rated flow rate per hour of each module (for instance, for some project with four modularized LSQWRF60VM/Na-M units, if the rated water flow of each unit is 10.3m³/h, then the required capacity of the whole project should be larger than 10.3*4*1/6=6.87m³). When water piping that is properly connected is quite short, a water tank is required to ensure an adequate flow rate inside the piping system.

NOTE

Do not treat the unit with saline mixture to prevent corrosion.

See the diagram below to install the water system.

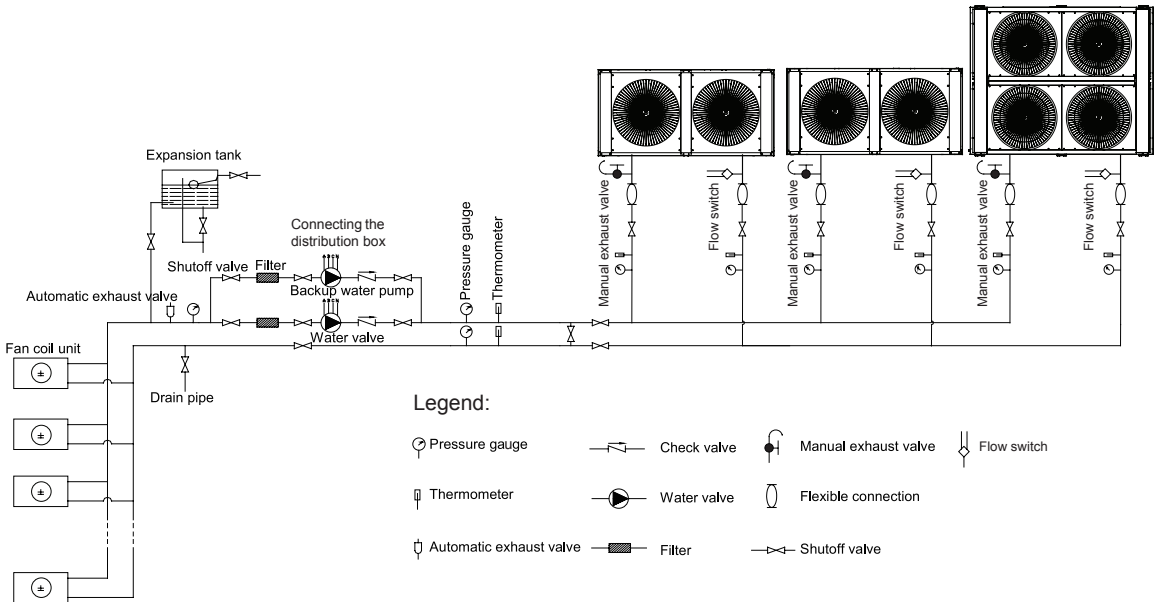

Follow the procedures below to drain the water system.

- (1) Loosen screws around the panel and then take down it.
- (2) Remove anticlockwise the blind plug located at the bottom of the heat exchanger to let the chilled water flow out, after that, tighten the blind plug and reinstall the panel. (Note: place the drainage equipment beneath the drain pipe to prevent pollution caused by the drain water.)

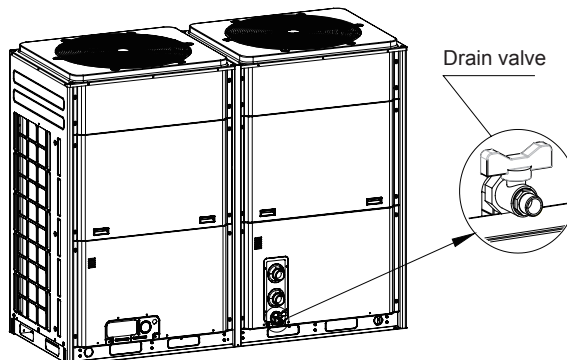

NOTE

Keep the purge valve of the water system open in order to drain the evaporator and condenser completely.

3.4.2 Requirements on piping

The piping slope should meet design and construction regulations and the flexible pipe is not allowed to be longer than 150mm.

Pipes which go through the dilatation joint and the settlement joint should be protected with the flexible joint.

No matter which connection is used, welding, threaded connection or flange connection, the connection joint can't be in the wall, floor or sleeve pipe.

The riser pipe should be installed vertically. When the floor height is or less than 5m, a pipe clip is required. When the floor height is or larger than 5m, at least 2 pipe clips should be required. The installation height of the pipe clip is 1.8m. For the main riser pipe, it should be secured with the fixed bolster to support the weight of the riser pipe.

See the table below for the installation standards of the pipes.

Item	Allowable deviation	Inspection method
Straightness	DN≤100mm	2L‰, max.440mm
	DN>100mm	3L‰, max.460mm
Verticality	25L‰, max.425mm	By the ruler, tape measurement
Interval of Parallel Pipes	15mm	By the ruler, tape measurement
Parallelism of Parallel Pipes	3mm	By the ruler, tape measurement

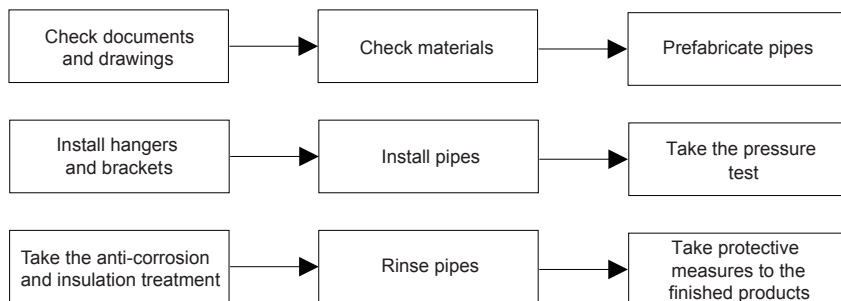
Piping flowchart**(1) Check documents and drawings**

- 1) Check the process flow, construction procedures and quality requirements in accordance with drawings and technical data.
- 2) Check the installation location, installation height, arrangement, and installation space of pipes in accordance with equipment drawings and building drawings.

(2) Check materials

- 1) Before installation, check for the mode of the valves, clean them and then take the strength and air-proof tests.
- 2) Pipes should be cleaned with a steel brush or abrasive paper. After that, seal the pipe ends and keep both the internal and external surface dry.
- 3) Pipes should be painted twice with anti-rust paint without any curtaining and voids.

(3) Prefabricate pipes

- 1) Make out the installation drawing which clearly indicates the branch pipes, pipe diameter, reduced pipes, location of valves, installation dimensions etc. Then, prefabricate pipes in accordance this installation drawing. Pipes should be processed with dedicated cutting machine, leaving no burrs at the pipe ends. After that, pipes should be cleaned to prevent sands and dusts from damaging the joint.
- 2) Pipe supports should be prefabricated in accordance with design requirements. The contact part between supports and pipes should be separated with wood blocks which has taken anti-corrosion treatment and is as thick as the insulation.

(4) Install hangers and brackets

- 1) The supporting beam should be fastened to the wall, pillar or other building structure. It should be placed horizontally with the top surface parallel with the center line of the pipe.
- 2) Pattern, installation, interval and standard height of supports for metal pipes should meet corresponding design requirements and codes.
- 3) Supports should be installed securely and contact the pipe closely. Separate supports are required at the connection joint between the pipe and the equipment.
- 4) Supports for chilled and cooling water pipes as well as main and branch pipes in the machine room should be anti-vibration.
- 5) When a single-bar hanger is used, anti-vibration hangers should be set up every 15m and at the pipe ends, valves, tee joints and elbows.

See the table below for the interval of brackets.

Diameter (mm)		15	20	25	32	40	50	70
Max interval between brackets (m)	Insulated pipe	1.5	2	2.5	2.5	3	3.5	4
	Non-insulated pipe	2.5	3	3.5	4	4.5	5	6
Max interval between brackets (m)	Insulated pipe	5	5	5.5	6.5	7.5	8.5	9.5
	Non-insulated pipe	6.5	6.5	7.5	7.5	9	9.5	10.5

△ NOTE

It is applicable to the pipes with working pressure less than 2.0 and insulation density less than 200kg/m³ or without any insulation.



(5) Install pipes

Supply and return water pipes with the diameter of being or being less than DN32 should be thread connected, and pipes with the diameter of being or larger than DN40 should be welded. Those which must be detachable should be flange connected. Before installation, foreign matters inside the pie should be removed.

Threads should be processed by the threading machine.

Use lead oil and oakum as stuffing materials and remove those outside of the threads after pipes have been installed.

Threads should be clean and at least 90% threads should be intact. Two or three spirals of threads should be exposed at the connection joint after installation without any exposed stuffing. Galvanized pipes should be protected and local damage should take anti-corrosion treatment.

3.4.3 Installation of the expansion tank

An expansion water tank should be installed for the closed-circuit water system to buffer water expansion and constriction as well as avoid effects on the water pipes caused by makeup water.

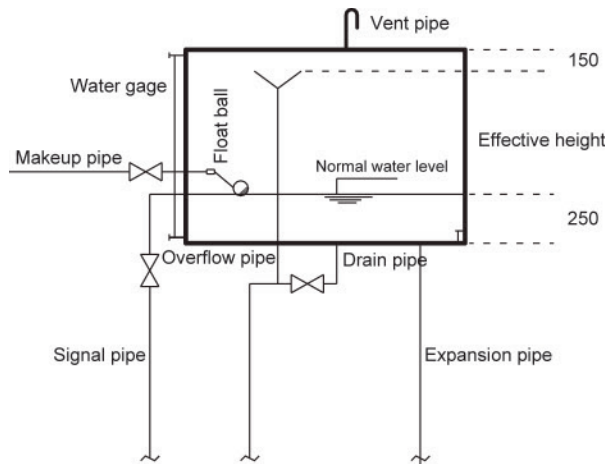

- (1) After the full water test, surface of the water tank should be de-rusted, finished and treated with anti-corrosion measure. The artificial anti-rust class should be st3.
- (2) After that, when water tank temperature is below 30°C, it should be painted with red lead rust-proof paint twice. When the temperature is among 30~70°C, it should be painted with chloroethylene 4~5 times. When the temperature is among 70~95°C, it should be painted with heat-resistant anti-rust paint 4~5 times. Do not do directly welding on the water tank with surface treatment.
- (3) The water tank should be installed horizontally and placed at a bar support which should go 100mm beyond at each side of the base plate. Height of the bar support should be no less than 300mm.
- (4) When water pipes are installed in the room without the heating system, the water tank, expansion pipe, circulating pipe, and signal pipe all should be insulated.
- (5) The installation height of the expansion water tank should be in the way that the lowest level of the water tank is at least 1m above the highest point of the water system.
- (6) For the mechanical circulating air-to-water system, in order to keep the expansion water tank and water system run normally, the expansion pipes of the expansion water tank should connect to the suction inlet of the circulating water pump. For the gravity circulating system, the expansion pipes should connect to the top of the main supply water riser pipe.
- (7) For the two-pipe air conditioning system, when there is only one expansion water tank for chilled and hot water, its effective volume should be figured out based on the heating conditions.

(8) When the water tank is or higher than 1500mm, it should have ladders both inside and outside of the water tank. When the water tank is or higher than 1800mm, it should have two glass gauges to indicate the water level.

(9) The circulating pipe should be connected to the main return pipe. Horizontal distance between the connection point to the constant-pressure point should be no less than 1500~3000mm.

3.4.4 Installation of condensate pipes

Setup → insulating → fastening

NOTE

- Adverse slope is not allowed for the slope larger than 1%.
- It can't connect with the rain water pipe, sewage pipe or other pipes.
- The elbow ventilator should be installed at the highest point of the condensate pipe to prevent foreign matters coming into the drain pipe.
- The S-shaped trap and flexible joint are necessary.
- The diameter of the pipes should be suitable.
- The wall-thru or floor-thru pipes should be protected by the steel sleeve. Do not put seams inside the sleeve. The steel sleeve should keep flush with floor, or 20mm above the floor for the floor-thru pipes. The steel sleeve is not allowed to affect the slope of the pipe and can't be used as the support of the pipe. Clearance between the pipe and the sleeve should be stuffed by flexible non-inflammable material.

(1) Setup

The condensate pipes should be at least 300mm away from the electric box of the unit. For special space, its installation location should be approved by the corresponding designers.

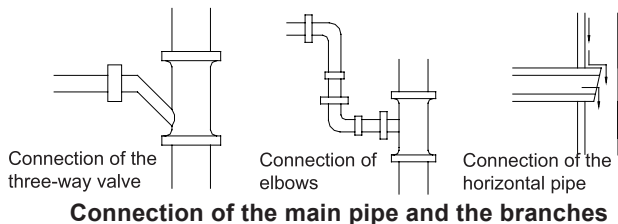
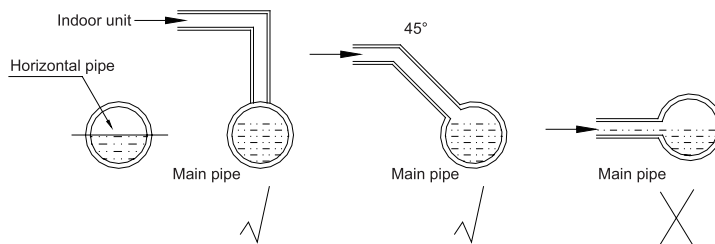

When the three-way valve is used for the condensate pipe, its straight two connectors should be kept at the same level as shown in the figure below.

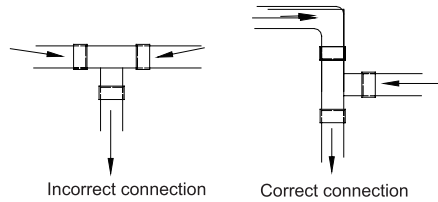

Tee joint

When there are several indoor units at the same floor, their condensate is usually drained out through one main pipe. In this case, the branches pipe for each unit should be located higher than the main pipe. The size of the condensate pipe is determined by the capacity and number of the indoor units.

Size of the tee drain pipe should match with the running capacity of the unit.

As pressure at the water outlet is quite large, an water trap is required for the drain pipe, which is applicable to the horizontal type air handing units and the indoor units of the duct type air conditioners.

$$A = P + 25\text{mm}$$

$$B = P/2 + 25\text{mm}$$

P indicates the the passive pressure (mmH₂O, 1mmH₂O=9.80665pascals) .

The pipe diameter should be or larger than 32mm.

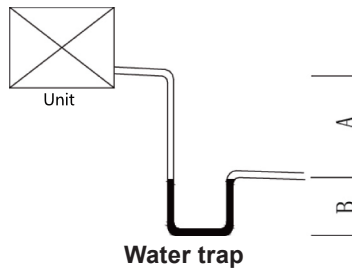

(2) Insulating

The extended drain pipe should be insulated and special care must be paid to the elbows. See the table below for the thickness of the insulation.

Drain pipe (mm)	Thickness of insulation (mm)
All	≥15

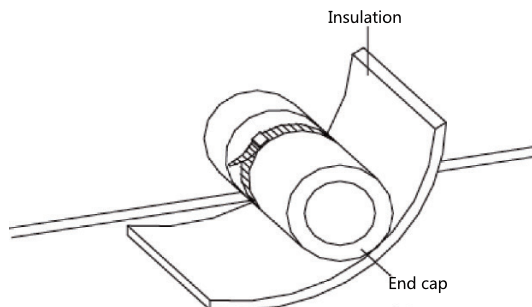

Insulation should be thickened at humid areas.

(3) Fastening

The insulating tube is just required to be bundled and fastened at the supporting bracket.

3.5 Electrical connection

3.5.1 Safety precautions

NOTE

- The electricians should be licensed.
- The air conditioning is Class I appliances and should be grounded reliably.
- The grounding resistance should comply with the national standards covered in GB 50169
- The yellow-green line is for grounding. Do not use it for other purpose or cut it off or fixed with the self-tapping screw, other wise it would lead to electric shocks.
- The power supply should be reliably grounded and do not connect the ground line to a) running water lines; b) gas lines; c) blow-off lines; d) other unreliable places.
- Do not make the power lines and communication lines entwined and arrange them separately with a distance no less than 20cm, otherwise it would lead to abnormal communication.
- Do not wire improperly power lines and communication lines. When the power line is wired to the communication port, it would make the main board burnt out.

3.5.2 External connection

Follow the wiring diagrams below to complete control output connections.

- LSQWRF35VM/NaA-M, LSQWRF35VM/NhA-M, LSQWRF60VM/NaA-M, LSQWRF65VM/NaA-M

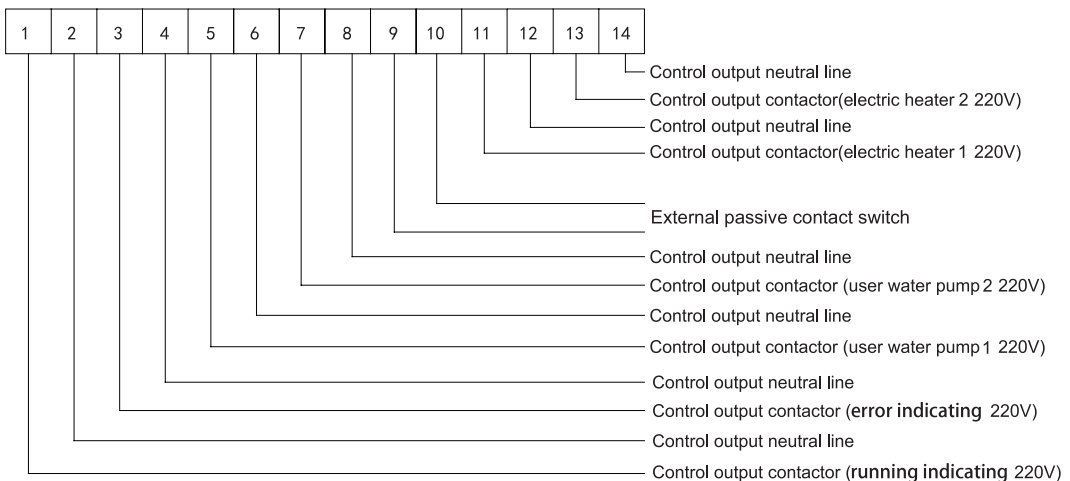

Note: the output control lines of the AC contactors for the running indicator, water pump 1, water pump 2, auxiliary electric heater 1, auxiliary electric heater 2 can be wired to the corresponding wiring board of all units, while those for the error indicator and external passive contact switch should be wired to the corresponding wiring board of all units.

Unit Installation

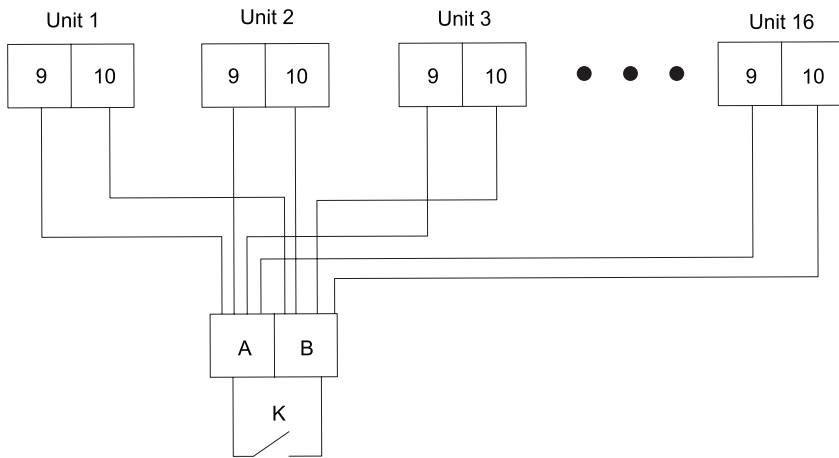

When external passive contact switch is available for multiple units, the wiring board 9 and 10 of each unit should be wired to the dry contact A and B.

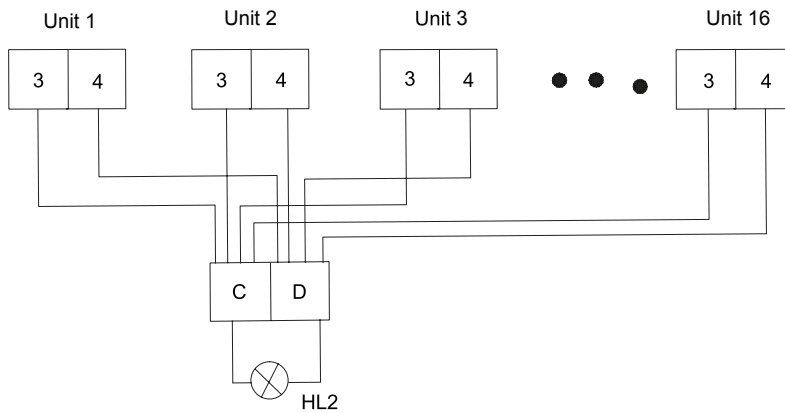

When it is required to display errors of several units, the wiring terminals (3, 4) of each unit should be wired to the wiring terminals HL2 (C, D) of the error indicator. (If it is required to display the error of each unit independently, then the error indicator of each unit should be wired independently to the corresponding error output wiring terminals (3,4) of each unit.

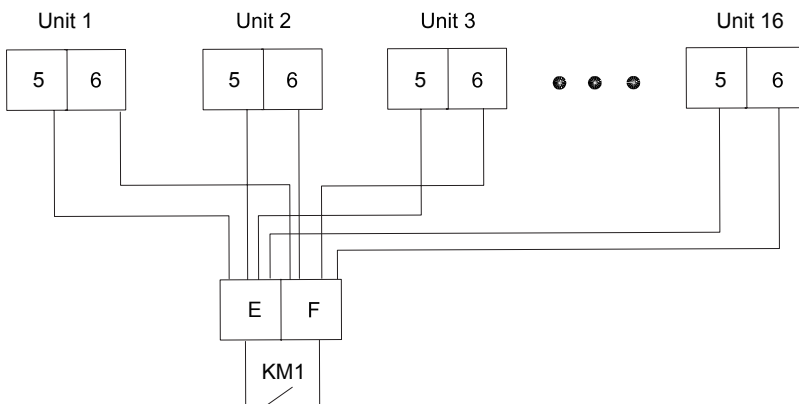

When multiple modules have direct control over one water pump, wiring terminals 5 and 6 for one modular unit are connected to terminals E and F respectively of the AC contactor (KM1) for the water pump, or 7 and 8 to E and F respectively of an AC contactor (KM2).

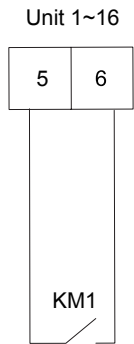

When multiple modules have direct control over one water pump, its AC contactor is wired to an AC contactor (KM1 or KM2) of any one module.

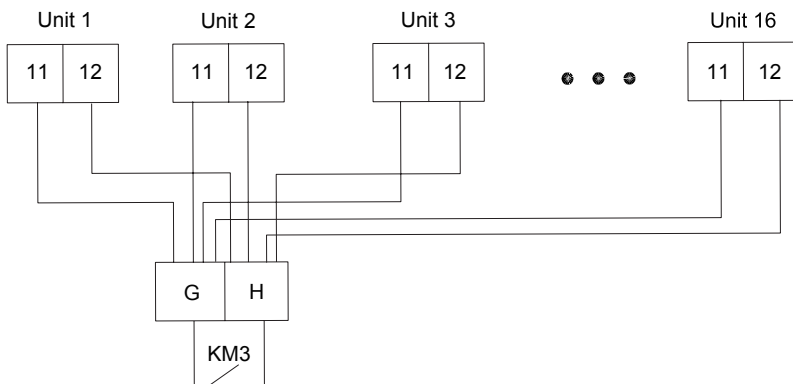

When one auxiliary electric heater serves more than one modules, its wiring terminals 11 and 12 are connected to terminals G and H respectively of an AC contactor marked with KM3.

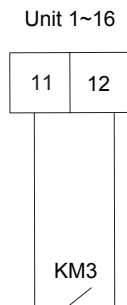

When multiple modules have direct control over one auxiliary electric heater, its AC contactor is wired to an AC contactor (KM3 or KM4) of any one module.

Unit Installation

■ LSQWRF60VM/NhA-M

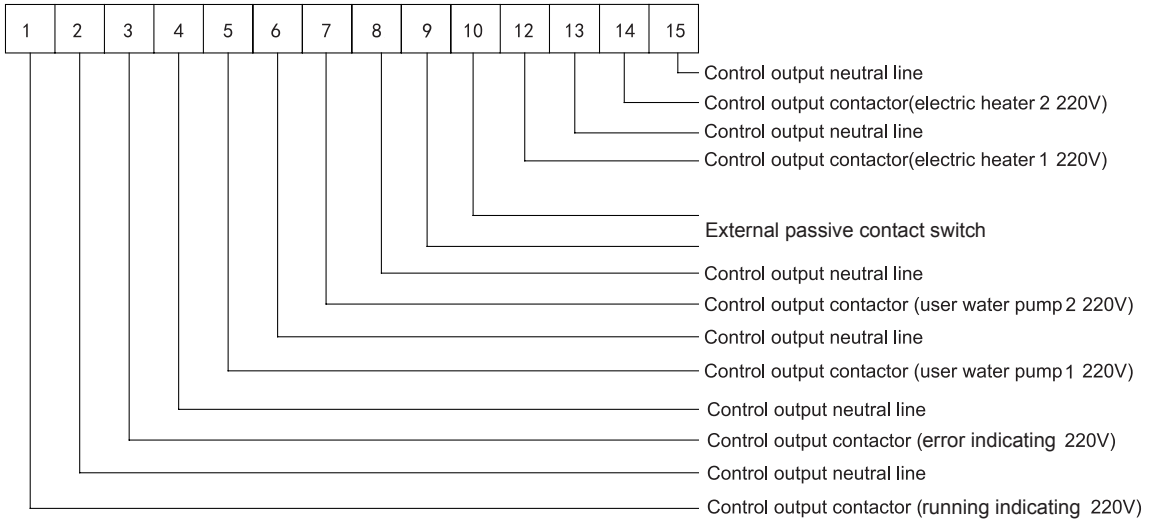

Note: the output control lines of the AC contactors for the auxiliary electric heater 1, auxiliary electric heater 2 can be wired to the corresponding wiring board of all units, while those for the error indicator and external passive contact switch should be wired to the corresponding wiring board of all units.

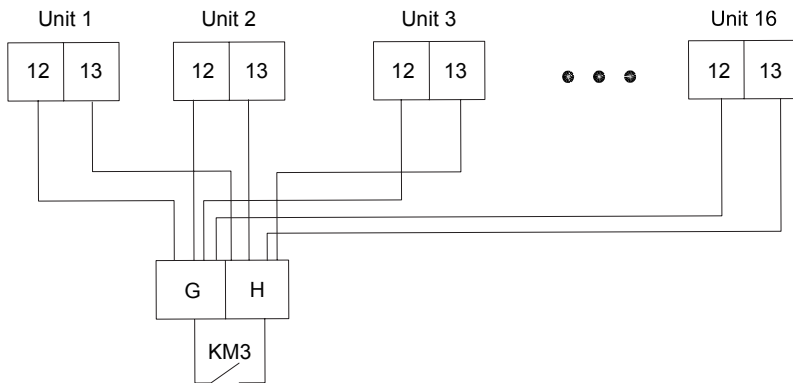

When one auxiliary electric heater serves more than one modules, its wiring terminals 12 and 13 are connected to terminals G and H respectively of an AC contactor marked with KM3

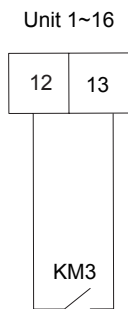

When multiple modules have direct control over one auxiliary electric heater, its AC contactor is wired to an AC contactor (KM3 or KM4) of any one module.

■ LSQWRF130VM/NhA-M

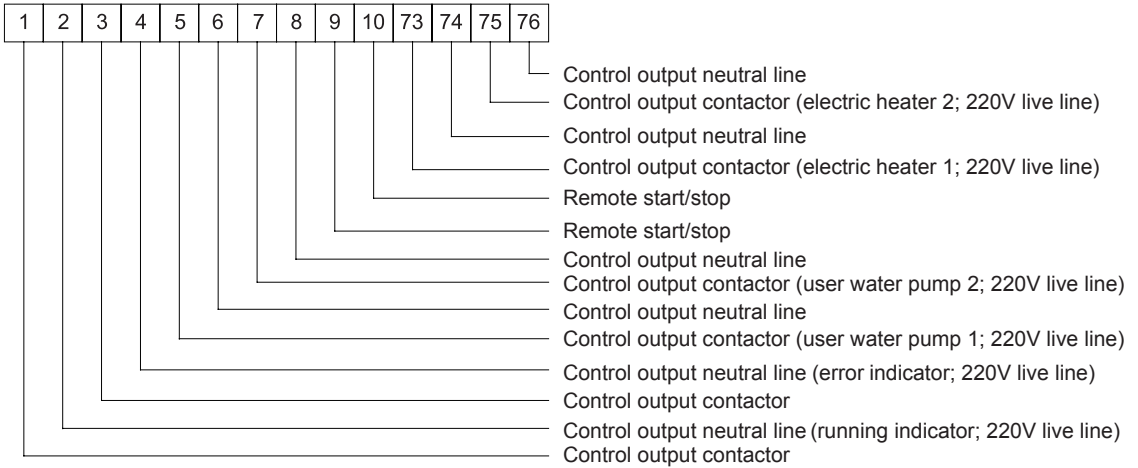

Note: the output control lines of the AC contactors for the auxiliary electric heater 1, auxiliary electric heater 2 can be wired to the corresponding wiring board of all units, while those for the error indicator and external passive contact switch should be wired to the corresponding wiring board of all units.

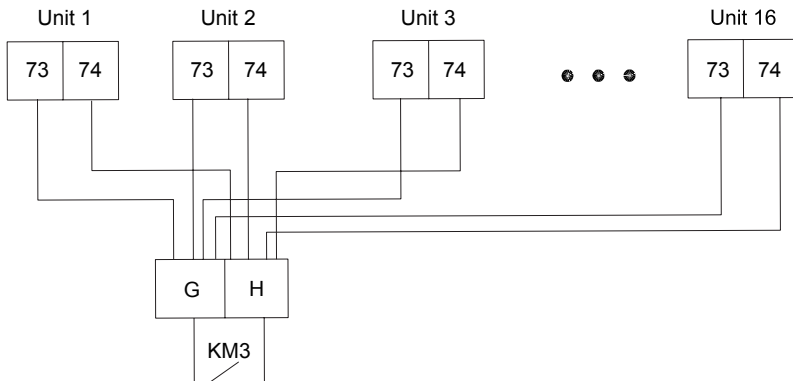

When one auxiliary electric heater serves more than one modules, its wiring terminals 73 and 74 are connected to terminals G and H respectively of an AC contactor marked with KM3

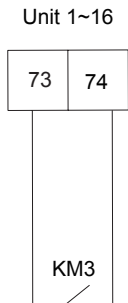

When multiple modules have direct control over one auxiliary electric heater, its AC contactor is wired to an AC contactor (KM3 or KM4) of any one module.

3.5.3 Specification of power supply

See the table below for selection of the power lines and the air switches.

Model	Power supply	Min. sectional area of the power cable (mm ²)			Capacity of the air switch (A)
		Live line	Neutral line	ground line	
LSQWRF35VM/NaA-M	380V–415VAC 3Ph 50Hz	6	6	6	32
LSQWRF60VM/NaA-M	380V–415VAC 3Ph 50Hz	16	16	16	63
LSQWRF65VM/NaA-M	380V–415VAC 3Ph 50Hz	16	16	16	63
LSQWRF35VM/NhA-M	380V–415VAC 3Ph 50Hz	6	6	6	32
LSQWRF60VM/NhA-M	380V–415VAC 3Ph 50Hz	16	16	16	63
LSQWRF130VM/NhA-M	380V–415VAC 3Ph 50Hz	35	16	16	150

Notes:

- (a) The specifications of the breaker and power cable listed in the table above are determined based on the maximum power (maximum amps) of the unit.
- (b) The specifications of the power cable listed in the table above are applied to the conduit-guarded multi-wire copper cable (like, JYV copper cable, consisting of PV insulated wires and a PVC cable jacket) used at 45°C and resistible to 90°C (subject to GB/T16895.15-2002). If the working condition changes, they should be modified according to the related applicable standard.
- (c) The specifications of the breaker listed in the table above are applied to the breaker with the working temperature at 40°C. If the working condition changes, they should be modified according to the related applicable standard.

3.5.4 Wiring of the electric control cabinet

(1) LSQWRF35VM/NaA-M, LSQWRF60VM/NaA-M, LSQWRF65VM/NaA-M, LSQWRF35VM/NhA-M

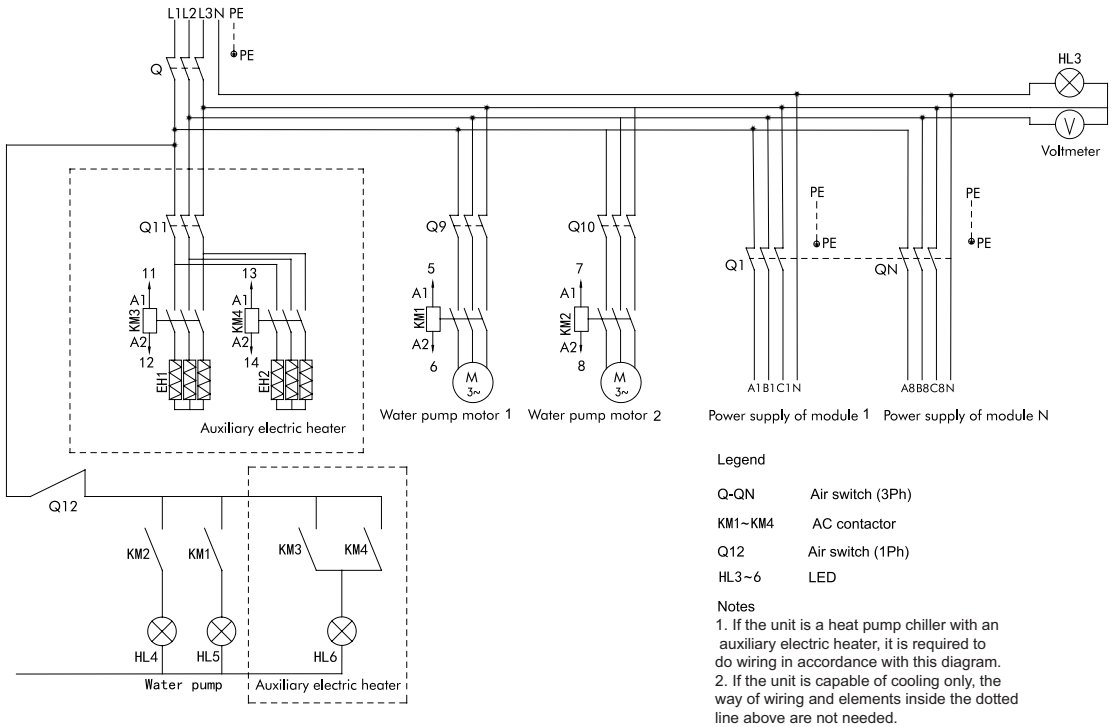

(2) LSQWRF60VM/NhA-M

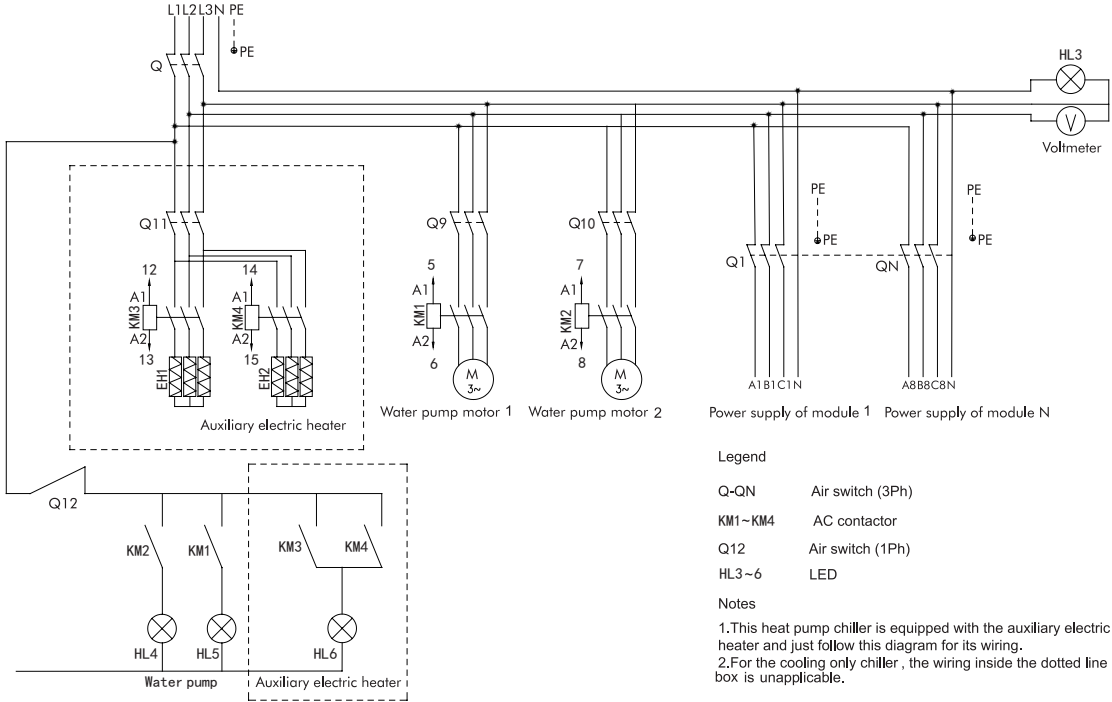

(3) LSQWRF130VM/NhA-M

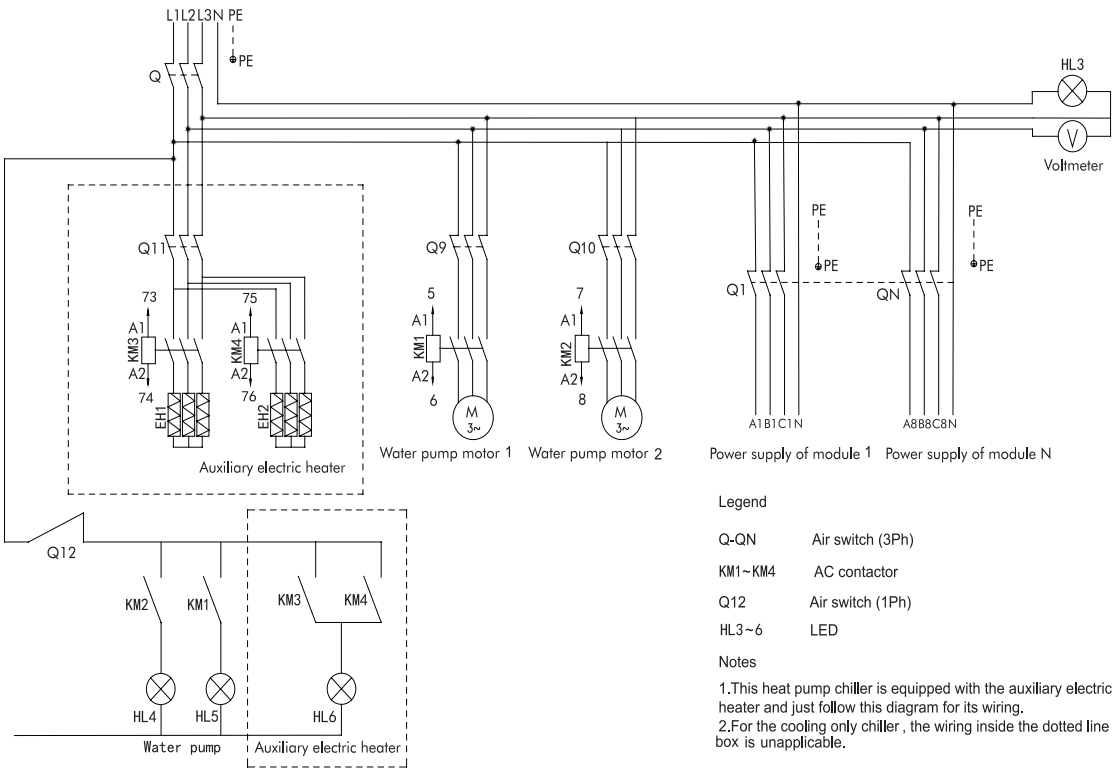

3.5.5 Field wiring

Follow the safety codes below.

- (1) All wiring shall comply with applicable codes and engineering requirements.
- (2) All field wiring shall be performed by qualified electricians.
- (3) Never perform wiring before the power supply is cut off.
- (4) Any damage caused by the improper external wiring shall be at the installer's expense.

WARNING

Only copper conductors are allowed.

Follow the procedures below to wire the power lines to the electric box.

- (1) The power cord must be routed inside the conduit.
- (2) The power cord must enter the electric box through a rubber or plastic ring to avoid any damaged caused by the sharp edge of the metal sheet.
- (3) The power cord close to the electric box must be attached securely to prevent the terminal block of the electric box affected by the outside force. The power cord shall be installed with a suitable cord anchorage against cord loosening. See the wiring diagrams below for external wiring.

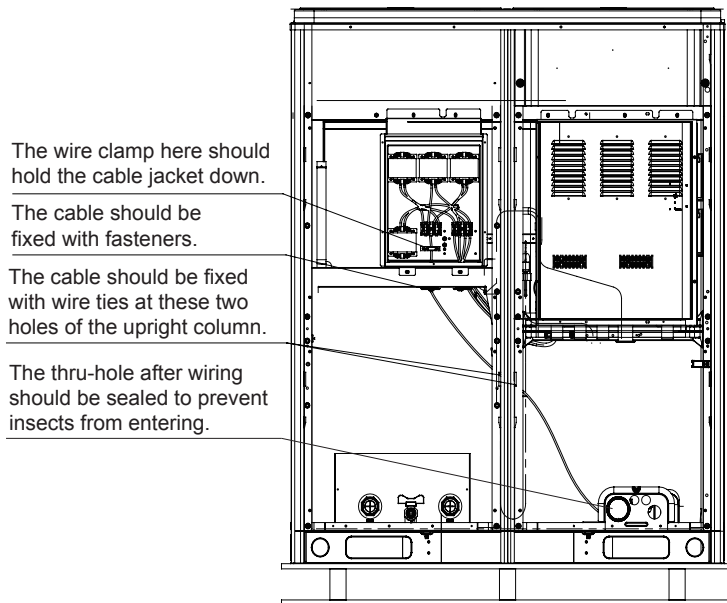

LSQWRF60VM/NaA-M, LSQWRF65VM/NaA-M

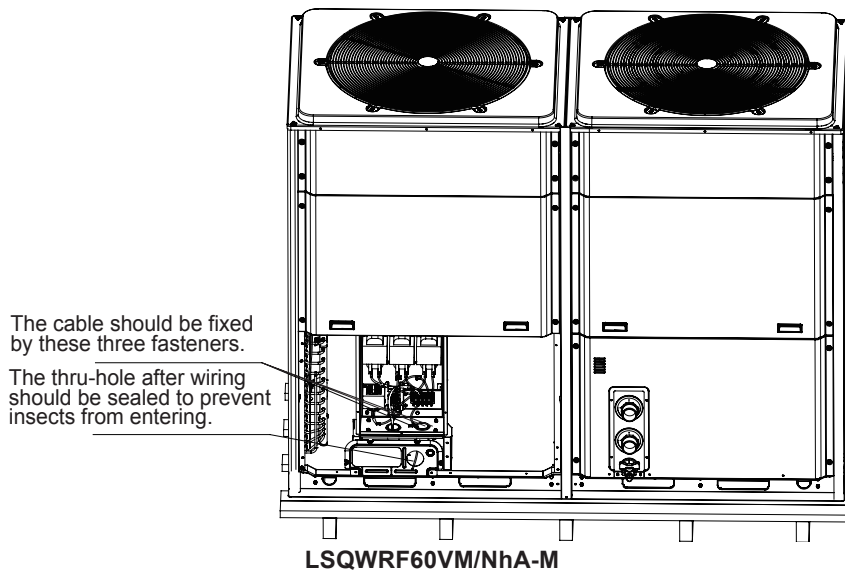

(4) The unit shall be grounded reliably and never connect the ground wire with the gas fuel pipe, water pipe, lightning rod or telephone line.

(5) After wiring, O-rings should be tightened to prevent coming of insects.

Follow the procedures below to connect control lines.

(1) The field supplied control line shall be at a minimum 1mm².

(2) The electric box will send the control signal (220 AC, 5A) to control the chilled water pump and auxiliary electric heater, however, never do not drive them directly through the control signal but through their AC contactors.

(3) Switching signals (220VAC, 2A) for the running and error indicators are available for the electric box.

(4) The remote switch control signal is available for the electric box and please pay attention to the input passive dry contact.

(5) A reasonable length of the control line should be left outside the unit and the rest should be bundled and fed into the electric box.

(6) The connection line of the display panel and main board is reliably grounded through the main board. Beside, communication lines between units also should be grounded.

3.5.6 Networking and wiring between units

(1) LSQWRF35VM/NaA-M, LSQWRF60VM/NaA-M, LSQWRF65VM/NaA-M, LSQWRF35VM/NhA-M

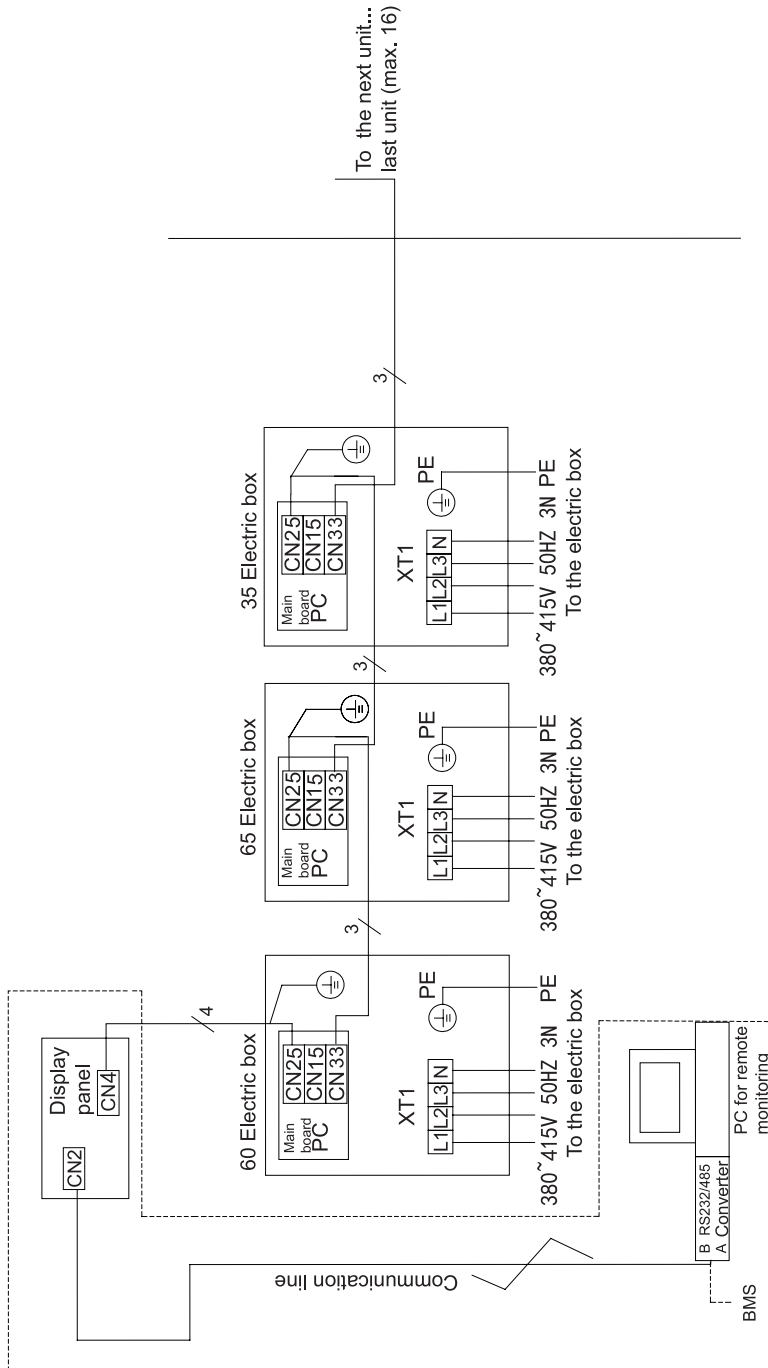

(2) LSQWF65VM/NaA-M, LSQWF130VM/NaA-M

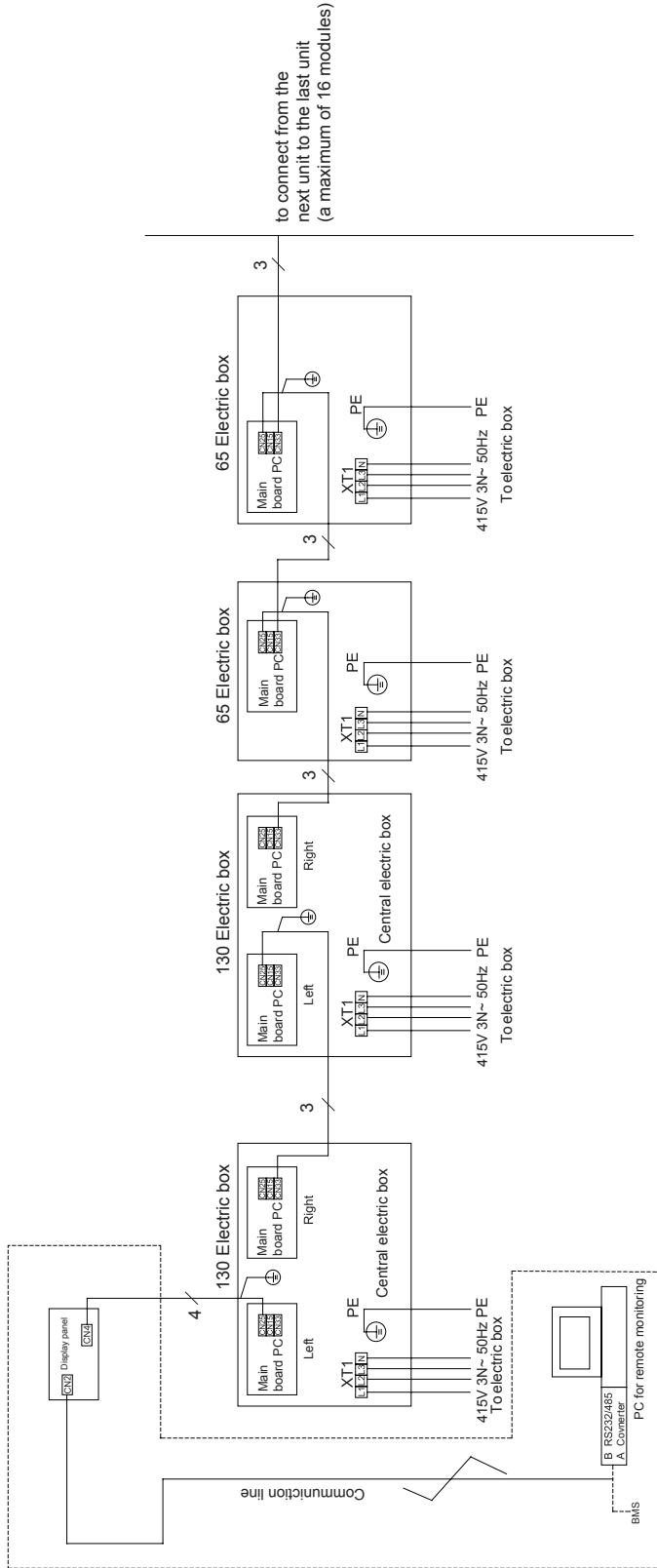







Notes:

- (a) As shown in the diagram above, CN33 and CN25 of all modules are connected by a three-core four-pin shielded communication line whose ground wires of both ends will be linked to the terminal near the main board.
- (b) As shown in the diagram above, CN4 on the display panel is connected to a CN25 on a main board of any unit by a four-core shielded communication line whose ground wire will be linked to the terminal near the main board.
- (c) The power lines should be connected to L1, L2, L3, and N at XT1 through a piece of four-core rubber sleeve cable as shown in the figure above.
- (d) There are two solutions for remote monitoring.
 - Install the remote monitoring software at the PC.
 - Based on GREE provided Modbus protocol, the user can do second development to this protocol.
 - Note: those enclosed by the dotted lines indicate the remote monitoring equipment. When the quantity of the display panel exceeds 30 or length of the communication line exceeds 800m, extra photoelectric relay is required. The photoelectric relays, communication lines (class 5 twist pairs), converters are optional. PC should be prepared by the user themselves.

3.5.7 Jumpers

When it is required to replace the main board, be sure the main board can match with the applicable jumpers.

Jumpers list

Model	Code	Jumper no.	Matched compressor
LSQWRF35VM/NaA-M	4202021905		QXAS-H80zN345H
LSQWRF60VM/NaA-M	4202021907		QXAS-H80zN345H
LSQWRF65VM/NaA-M	4202021906		QXAS-H80zN345H
LSQWRF35VM/NhA-M	4202021913		QXFS-H80zN345H
LSQWRF60VM/NhA-M	4202021915		QXFS-H80zN345H
LSQWRF130VM/NhA-M	4202021916		QXFS-H80zN345K

Test Operation, Troubleshooting and Maintenance

4 Test operation, troubleshooting and maintenance

4.1 Commissioning

4.1.1 Flowchart of commissioning

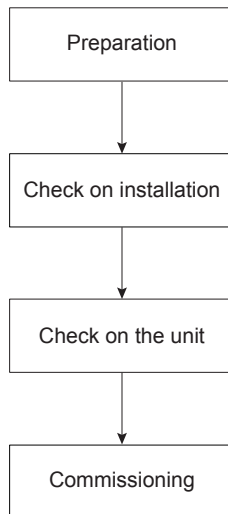

4.1.2 Safety precautions for commissioning



WARNING

- Safety measures should be taken during indoor operation. Any commissioning and service personnel should grasp and observe safety regulations of construction work.
- Refrigeration mechanic, electricians, welders and other technicians of other special work all should be licensed.
- Power supply should be cut off before any operation to the unit. Meanwhile, please observe required safety operation.
- All installation and operation should comply with design requirements of this product and local safety requirements.
- Never force the compressor to run by electrifying it directly.

4.1.3 Preparation before commissioning

- (1) Manual of installation instructions
- (2) Certificate of qualification
- (3) Electric wiring diagrams
- (4) Sheet of saturated temperature and pressure

4.1.4 Check before commissioning

◆ Check the completeness

- (1) Is the surface of the unit in good condition?
- (2) Is there leak at any pipe connector?
- (3) Is any part damaged?

◆ Check installation of the unit

Do the installation location, installation foundation and maintenance space comply with corresponding requirements?

◆ Check the water system

- (1) Is the water flow direction in the condenser and evaporator correct?
- (2) Are the chilled water pipes clean? Is there any foreign matter trapped in the joints? Is the water quality satisfactory?
- (3) Is the insulation of the chilled water pipes in good condition?
- (4) Are the manometer and thermometer connected correctly (Is the manometer at a right angle with the water pipe, and is the thermometer's probe inserted into the water pump)? Do the initial values of the manometer and thermometer comply with requirements before commissioning?
- (5) Is the leaving water flow switch installed correctly? Is this flow switch correctly wired to the electric control cabinet?
- (6) Start the chilled water pump through the contactor and see: does the chilled water pump run in the correct direction (-clockwise)? If not, check the wiring of the water pump.
- (7) Run the chilled water pump and see: is the water pressure stable? do the reading values of water pressure change slightly? Is the running ampere in the rated range? If not, just handle all of them.
- (8) Does the water makeup device of the expansion water tank work well? Does the automatic exhaust valve work well? For the hand exhaust valve, open it to exhaust air inside the system.

◆ Check the work load

- (1) Are the air handling units connected correctly?
- (2) Do all diffusers work smoothly?
- (3) Are the tightness and insulation of the conditioned space in good condition?
- (4) Does the required load match with the capacity of the unit?

 **WARNING**

- Do not check the power supply without any proper detection device and preventive measures, or it would lead to severe injuries or even death.
- Each single unit should be supplied with dedicated power lines. After wiring, check the following items one by one.
 - 1) Is the size of the air switch proper?
 - 2) Does all electric installation meet corresponding electric standards or codes?
 - 3) Is all wiring correct?
 - 4) Are all interlocks work well?
 - 5) Do all contacts work well?
 - 6) Are the power supply and insulation in good condition?
 - 7) Is the setpoint of the control and protection elements correct?

4.1.5 Check for initial run

Check for initial run should be performed by four steps as shown below when the unit is ready for initial run.

◆ Check for communication

Check if the displayed number of modules is the same as the real number. If so, it indicates communication goes normal. If not, take the following inspections.

- (1) Are all connected units powered on?
- (2) Does each single unit have a unique address?
- (3) Is there any single unit which has not been detected by the control? Is the communication line of the mainboard connected correctly or is the communication line itself non-defective?

◆ Check for a single unit

- (1) Commission one single unit first and stop all others.
- (2) Do the compressor, fans and the 4-way valve run normally without any unusual noise?
- (3) Is the voltage phase difference lower than $\pm 2\%$?
- (4) Voltage phase difference = $(\text{phase difference between the max and average voltage}) / (\text{average voltage}) \times 100\%$.
- (5) Start up this single unit.
- (6) Do its compressor, fans and the 4-way valve run normally without any unusual noise?
- (7) Check other units one by one in the same way.

◆ Check for the water flow of a single unit

In order to prevent the water temperature changing too quickly, it is suggested to open all terminal units in commissioning, and observe and record the pressure drop of the manometers at the outlet and inlet pipes. Also, adjust the flow control valves or shut-off valves to make the flow meet application requirements.

When the environmental temperature is available, let the unit perform cooling ($>15^{\circ}\text{C}$). When the unit has run stably for 10 minutes, the normal difference of the entering and leaving water should be $4\text{-}6^{\circ}\text{C}$.

- (1) If the temperature difference is larger than $4\text{-}6^{\circ}\text{C}$, raise it by reducing the water flow of other units.
- (2) If the temperature difference is smaller than $4\text{-}6^{\circ}\text{C}$, ignore it in the event that the difference of other units is suitable, and reduce the water flow of this unit in the event that the difference of other units is also unsuitable.
- (3) Check for the water flow of other units one by one in the same way.

◆ Check for operation of the whole unit

- (1) Check the difference of the entering and leaving water temperature of each unit when the whole unit has been in operation. If temperature adjustment fails, reconsider the capacity of the selected water pump.
- (2) Start up the whole unit under the full load. When the whole unit has run stably for one hour, check if the water temperature and the air conditioning effect meet the user's requirements.
- (3) Observe and record the entering and leaving water temperature, condensing and evaporating pressure. Then, stop the unit and check the setpoint of each parameter on the control panel. After that, complete the commissioning data sheet.
- (4) When the unit comes to the protection state, diagnose it and and seek solutions.

4.2 Troubleshooting

4.2.1 Diagnostics

Diagnostic name	Affects signal source	Description
High pressure protection	High pressure cutout	<p>When the pressure is too high or the current exceeds the setpoint, the corresponding compressor will stop and the indicating LED on the control panel will light on and the error information will be displayed on the error log. The error must be manually cleared for normal operation of next time.</p>
Low pressure protection	Low pressure cutout	<ul style="list-style-type: none"> • When it is detected the low-pressure cutout of the compressor is opened frequently, the compressor will be shut down immediately. • Meanwhile, the error information will be displayed. The error must be manually cleared for normal operation of next time.
High discharge protection	Discharge temperature sensor	<p>When it is detected that the discharge temperature exceeds the setpoint, the compressor will be shut down immediately. Meanwhile, the error information will be displayed among the error log. The error must be manually cleared for normal operation of next time.</p>
Temperature sensor protection	Temperature sensor	<ul style="list-style-type: none"> • When the entering water temperature fails, all compressors and fans of the corresponding single unit will stop. When the discharge temperature sensor fails, the display panels will tell "Discharge temperature sensor X error". • In this case, the unit can be started normally only when it has been unlocked. When the antifreeze temperature sensor or leaving water temperature sensor fails, the display panel will display this error. In this case, the unit can resume normal operation only when the error is cleared manually.

Diagnostic name	Affects signal source	Description
Communication fault	Main board	When the single unit fails to receive signals from the control panel, it will automatically be shut off.
Phase loss/reversal protection	Phase protector	When phase loss/reversal occurs, the phase protector will cut off the power supply to the main board.
Protection for the water flow switch	Contact	When a single unit detects its flow switch is open, this module will automatically be shut down. When all flow switches are closed, the water pump will stop.
Protection for the four-way valve	Entering and leaving water temperature sensors	When it is detected that the entering water temperature is 4°C higher than the leaving water temperature and the latter continuously goes down, the compressor will be stopped immediately and the control panel will display this error.
Protection for the compressor IPM module	Drive board of the compressor	When it is detected that the compressor IPM current or temperature is higher than the setpoint, the compressor will be stopped immediately and the control panel will display this error.
Protection for the fan IPM module	Drive board of the fan	When it is detected that the fan IPM current or temperature is higher than the setpoint, the compressor will be stopped immediately and the control panel will display this error.

4.2.2 Flow chart of troubleshooting

(1) High pressure protection

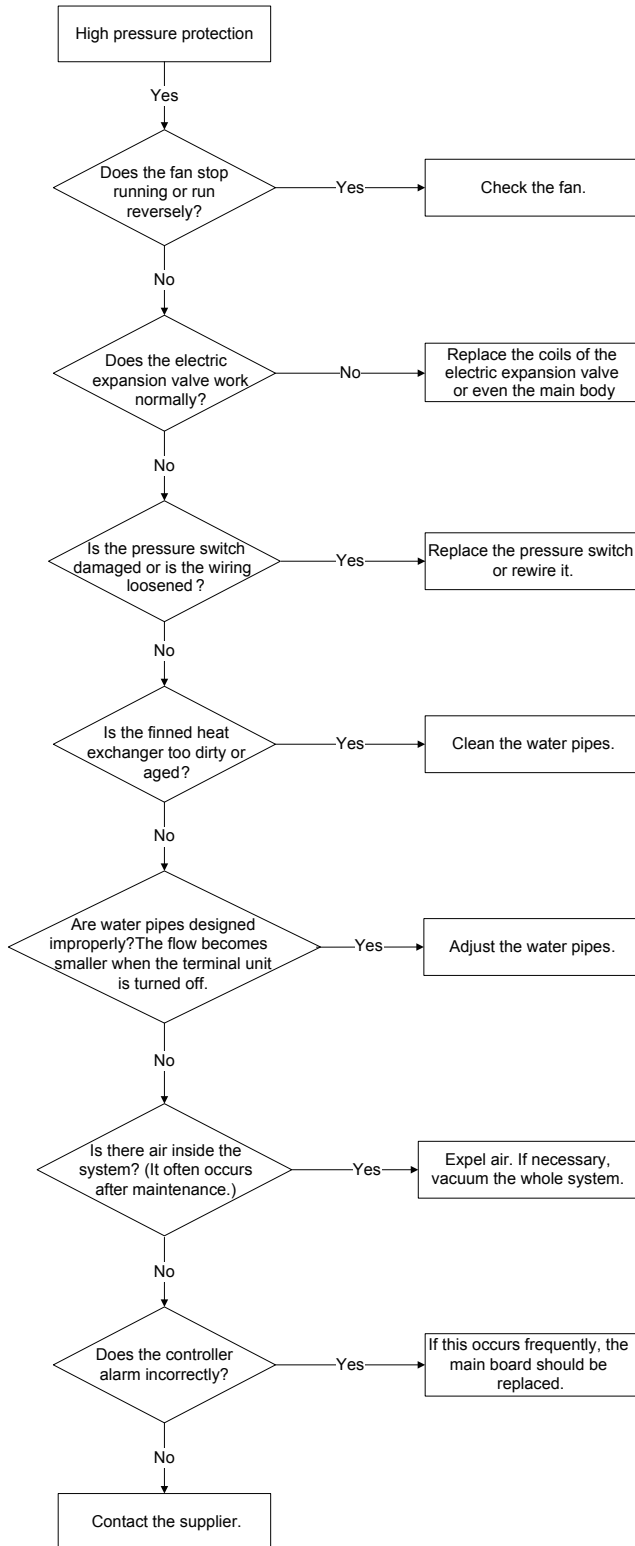

(2) Low pressure protection

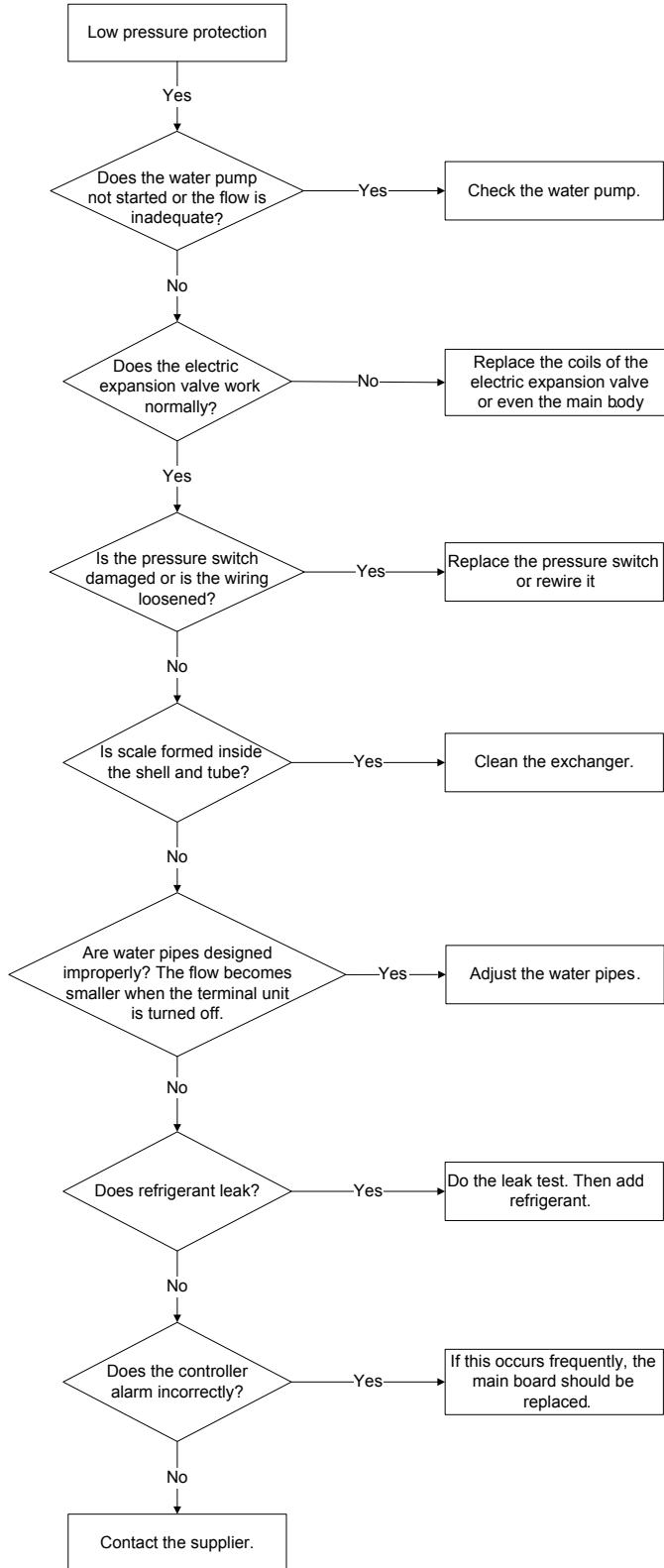

(3) High discharge protection

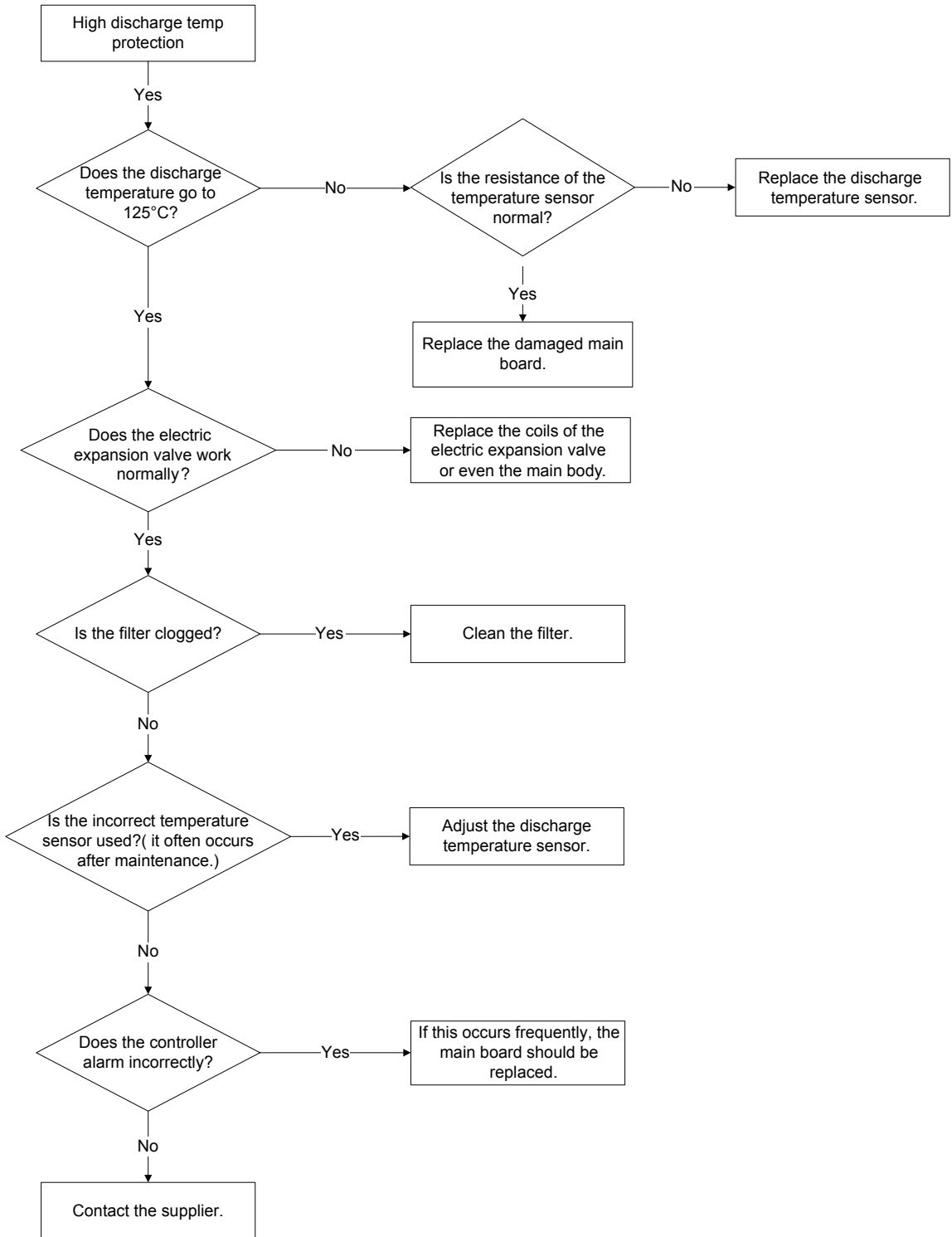

(4) Phase protection

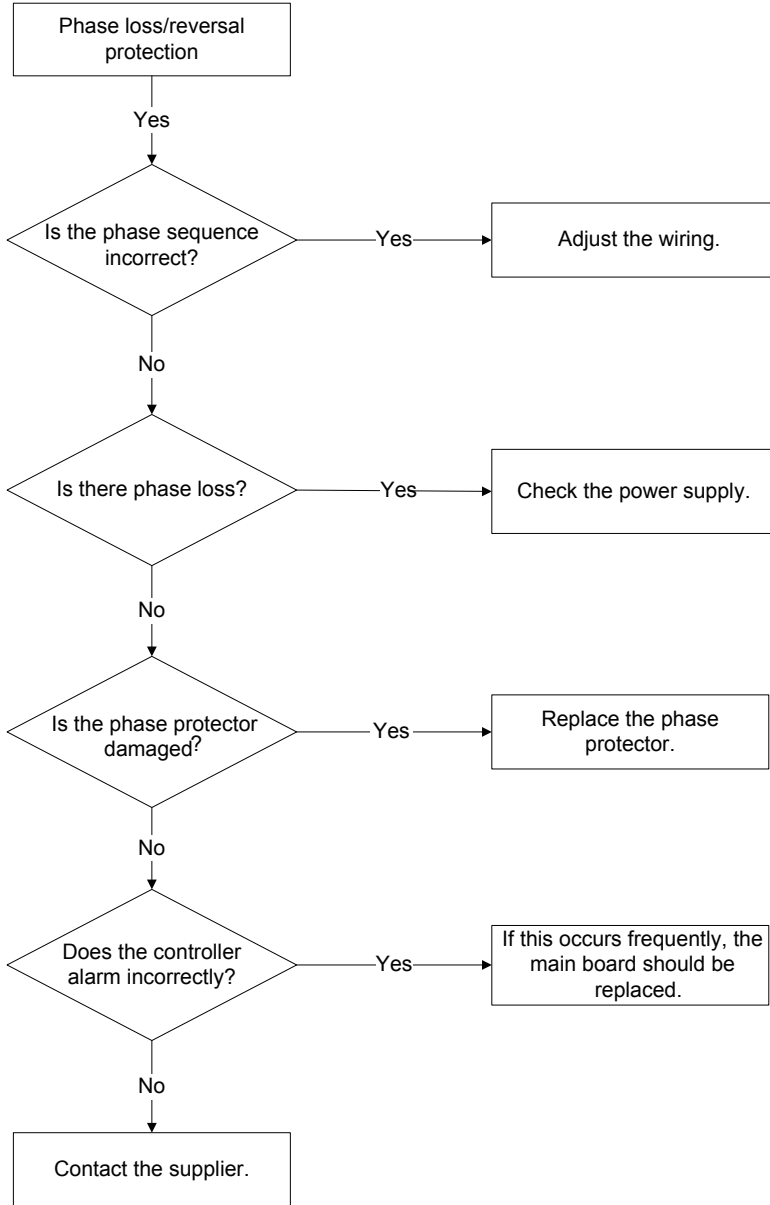

(5) Water flow switch protection

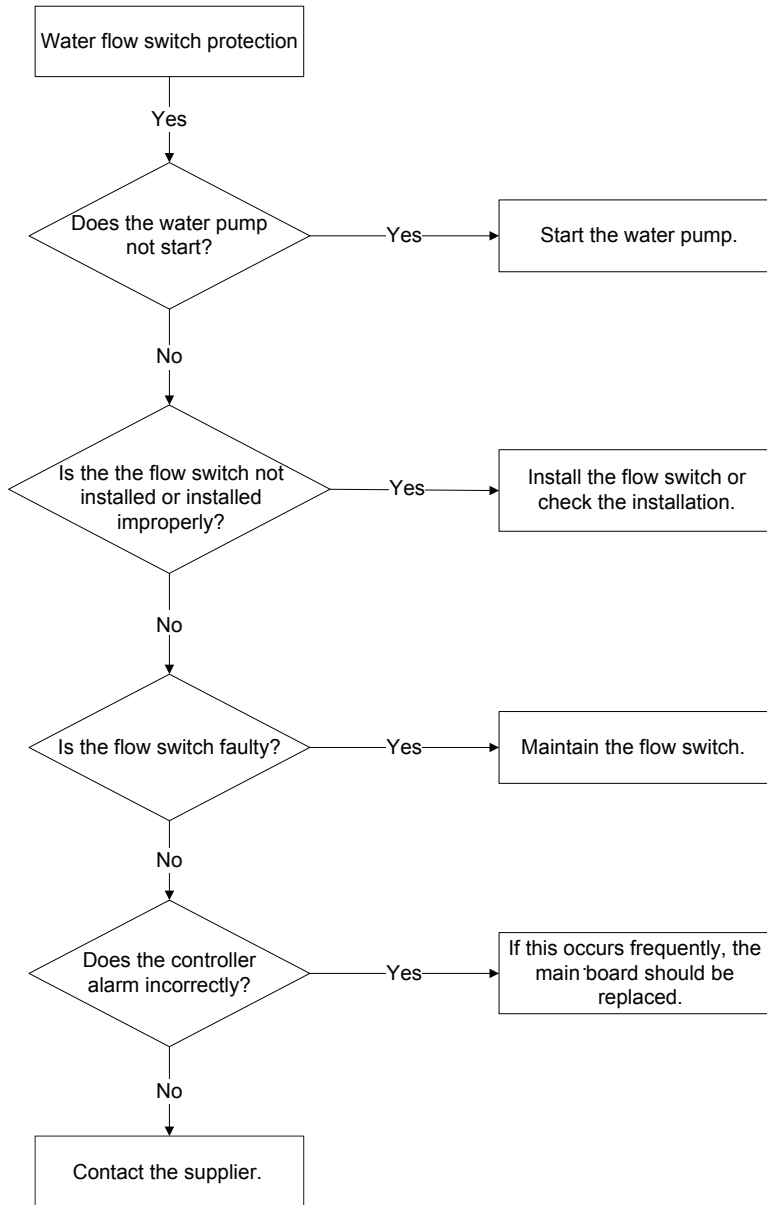

(6) Temperature sensor error

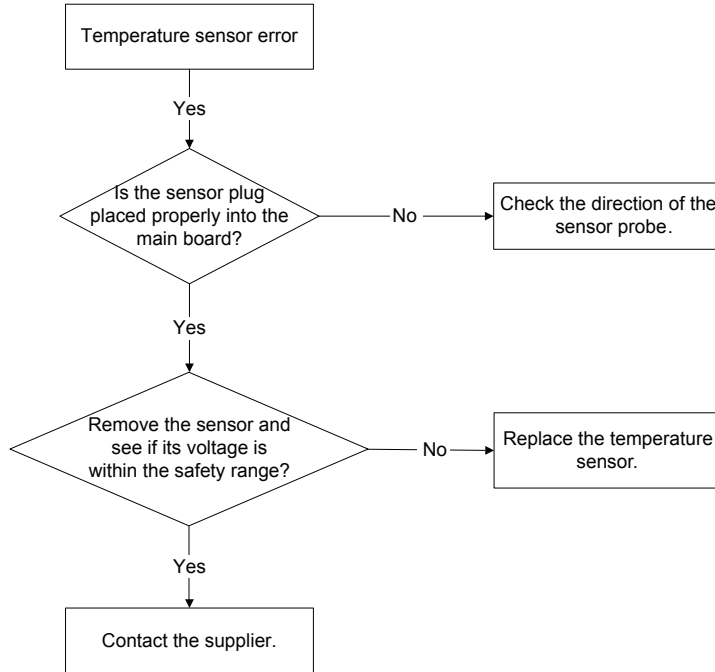

(7) Protection for the four-way valve

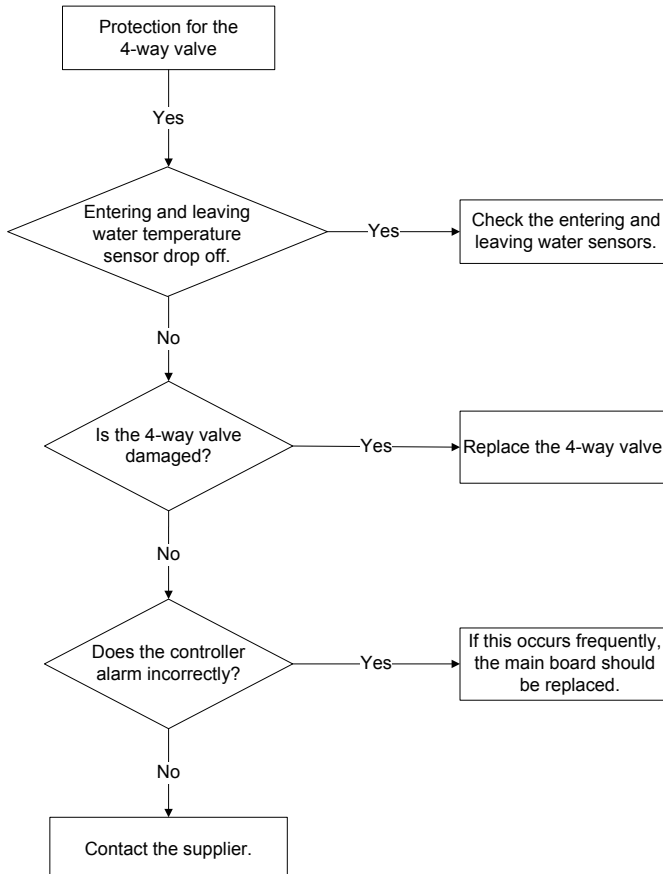

4.3 Power distribution

4.3.1 Power distribution logic

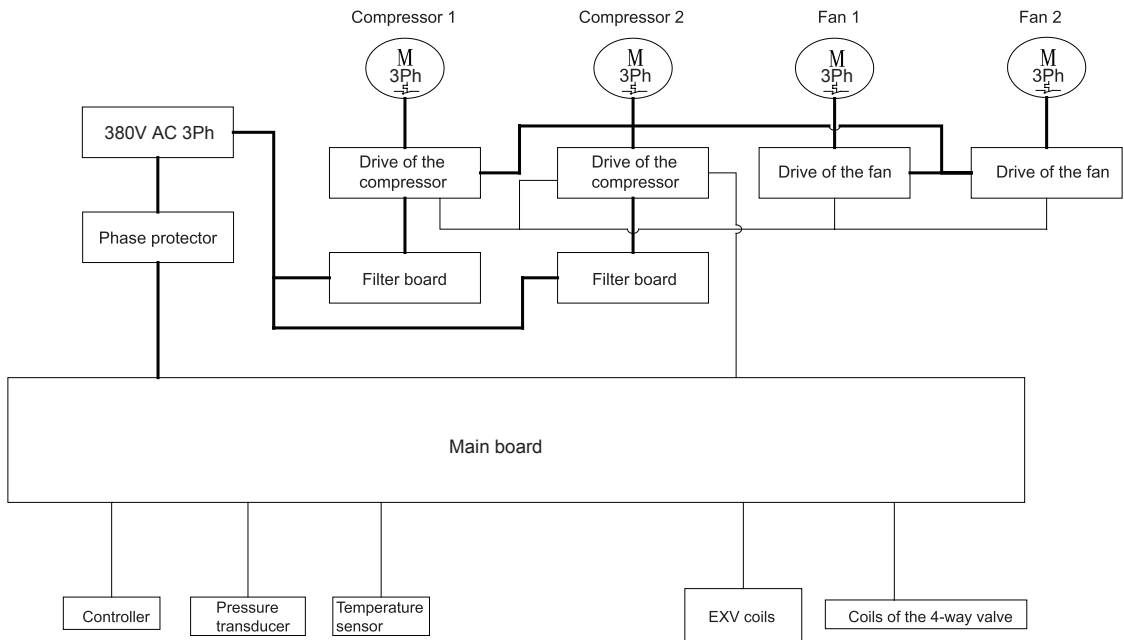



Note: bold lines indicate the main circuit and slim lines indicate the control circuit.

Protection conditions: phase loss or reversal of the power input for the phase protector.

Action result: No power for the controller and ON/OFF operation is failed.

Handling: interchange the wiring sequence and check if the voltage of the 3-phase power supply is normal.

4.3.2 Introduction to main electric elements

Image	Name	Description
	Phase loss/reversal protector	It is used to check if the phase sequence of the power supply is correct or if there is power loss.
	Intermediate relay	It is used for the running and fault indicators.

4.3.3 Main board

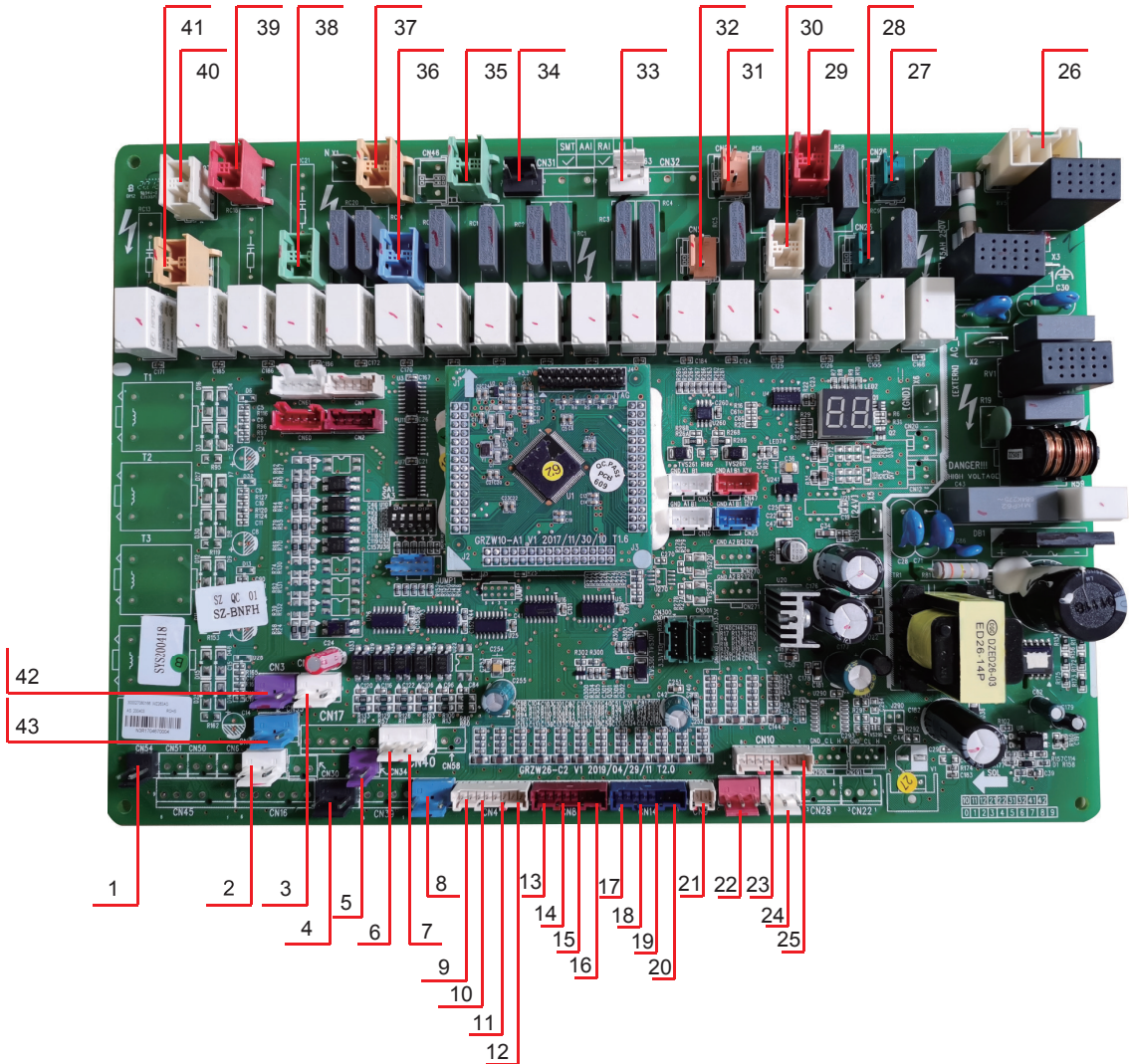





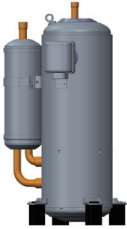

No.	Name
1	Water flow switch
2	System 2 low-pressure switch for heating
3	System 1 high-pressure switch
4	System 1 low-pressure switch for heating
5	External passive contact switch
6	Preserved
7	Preserved
8	System 1 low-pressure switch for cooling
9	System 1 discharge temp. sensor
10	System 1 defrosting temp. sensor
11	Anti-freezing temp. sensor
12	Leaving water temp. sensor
13	Inlet water temp. sensor

No.	Name
14	Preserved
15	System 2 defrosting temp. sensor
16	System 2 discharge temp. sensor
17	System 1 shell-and-tube inlet temp. sensor
18	System 2 shell-and-tube inlet temp. sensor
19	System 1 suction temp. sensor
20	System 2 suction temp. sensor
21	Outdoor ambient temp. sensor
22	System 1 high pressure sensor
23	System 2 shell-and-tube outlet temp. sensor
24	System 2 high pressure sensor
25	System 1 shell-and-tube outlet temp. sensor
26	220V input
27	COMP2 band heater 2
28	COMP2 band heater 1
29	4-way valve 2
30	4-way valve 1
31	COMP1 band heater 2
32	COMP1 band heater 1
33	Bottom band heater 2
34	Bottom band heater 1
35	Water pump 1
36	Auxiliary electrical heater 1
37	Auxiliary electrical heater 1
38	Water pump 2
39	Error indicating
40	Solenoid valve 2
41	Solenoid valve 1
42	System 2 high-pressure switch
43	System 2 low-pressure switch for cooling

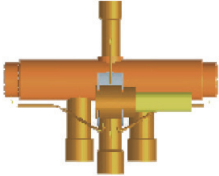
4.4 Replacement of main parts

4.4.1 Brief introduction

Image	Name	Function
	Compressor	It is the power source of the whole system, used to compress low-pressure and low-temperature refrigerant to be high-pressure and high-temperature gas.
	Vapor-liquid separator	It is intended to separate refrigeration oil from liquid refrigerant.
	Four-way valve	It is used to control the flow direction of refrigerant for either heating or cooling.
	Shell-and-tube heat exchanger	It is intended to conduct heat exchange between the refrigerant and the second refrigerant.
	Finned heat exchanger	At the cooling mode, it is intended to turn the high-temperature high-pressure refrigerant vapor into refrigerant liquid by releasing heat to the cooling medium. At the heating mode, it is intended to vaporize refrigerant liquid by absorbing heat from the cooling medium.
	Electric expansion valve	It is intended to control refrigerant flow rate to make it match with the required load and make the refrigerant flowing into the evaporator evaporate completely.

4.4.2 Replacement instructions

(1) LSQWRF35VM/NaA-M and LSQWRF35VM/NhA-M

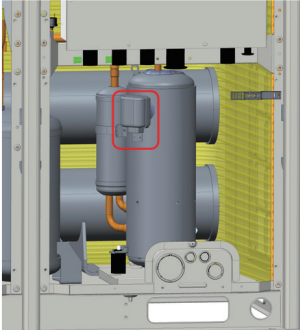
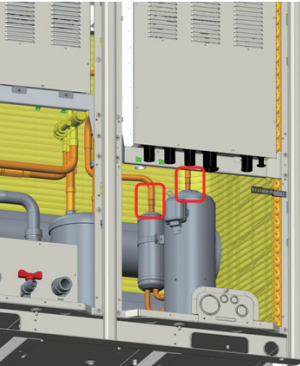
Replacement of the compressor		
Note: be sure there is no refrigerant inside the system and power supply has been cut off before replacement.		
Steps	Image	Instructions
1. Remove the front panels.		<ul style="list-style-type: none"> Remove screws at the front pane. Loosened screws should be put together to avoid loss. Pull the front panel upwards and then remove it. Properly keep the removed front panel to avoid from being damaged. Note: there are two clasps at each panel for connecting with side panels.
2. Remove power lines and the electric heater.		<ul style="list-style-type: none"> Remove the insulation of the compressor. Loosen screws of power lines with a screwdriver. Draw out power lines. Draw out the electric heater. Note: power lines and their terminals should be numbered to avoid incorrect rewiring.
3. Disconnect power lines to the compressor.		<ul style="list-style-type: none"> Desolder pipes quick to avoid deformation. Keep the replaced compressor complete for further analysis.

Replacement of the compressor

Note: be sure there is no refrigerant inside the system and power supply has been cut off before replacement.

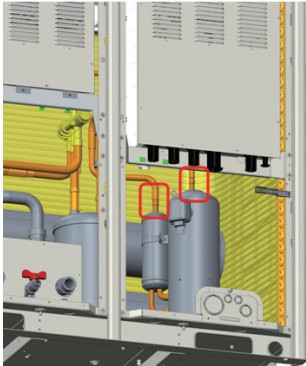
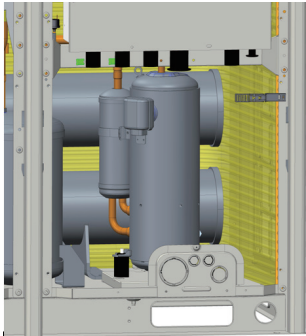
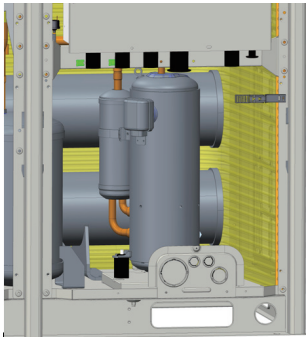
Steps	Image	Instructions
<p>4. Loosen screws at feet of the compressor.</p>		<ul style="list-style-type: none"> • Loosen screws at feet of the compressor with a adjustable or box spanner. • Loosened screws should be put together to avoid loss.
<p>5. Replace the compressor with a new one.</p>		<ul style="list-style-type: none"> • During replacement, care must be taken to not damage rubber pads. • Seal the replaced compressor to prevent moisture entering; • Place a new compressor at the rubber pads. Steel bushing is required for rubber pads. • Tighten the steel bushing with screws.
<p>6. Reconnect the suction line, the discharge line, other pipes and electric lines. Then, check for normal operation of the compressor.</p>		<ul style="list-style-type: none"> • Reconnect and resolder the suction and discharge lines. Do charge nitrogen during soldering. • After soldering, charge high-pressure nitrogen for the leak test. • Power on the unit and start it through a AC contact for 2~3 seconds. • When the compressor runs reversely, it would generate harsh noise.

Replacement of the compressor

Note: be sure there is no refrigerant inside the system and power supply has been cut off before replacement.

Steps	Image	Instructions
7. Put back the front panels.		Put back front panels and tighten screws.

Note: there would be trapped oil inside the compressor during replacement, which would not affect its reliability but increase resistance to the rotors and then consume more power. In order to expel it, it would be better to install another valve at the lower point of the suction line. After that, run the compressor for ten minutes and then open this valve until no oil comes out. Repeat this operation twice for normal oil level.

Replacement of the 4-way valve

Note: be sure power supply has been cut off and refrigerant has been reclaimed before replacement.

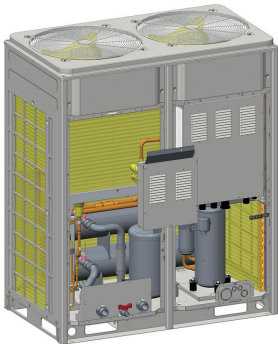
Steps	Image	Instructions
1. Remove the front panel.		<ul style="list-style-type: none"> • Remove screws at the front panel; • Loosened screws should be put together to avoid loss. • Pull the front panel upwards and then remove it. • Properly keep the removed front panel to avoid from being damaged. • Note: there are two clasps at each panel for connecting with side panels.
2. Remove the electric control box.		<ul style="list-style-type: none"> • Disconnect electric lines inside and outside of the electric box. • Protection measures should be taken to the internal elements to prevent them from being damaged.

Replacement of the 4-way valve

Note: be sure power supply has been cut off and refrigerant has been reclaimed before replacement.

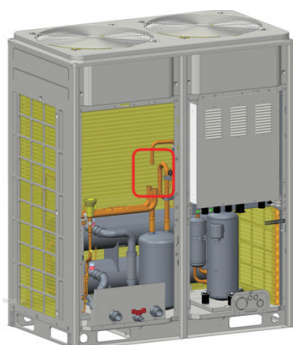
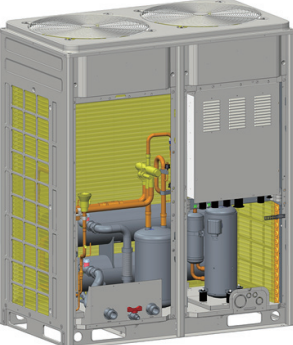
Steps	Image	Instructions
<p>3. Record the direction of the 4-way valve before desoldering. The multi-system unit can not take other system as a example.</p>		<ul style="list-style-type: none"> • Remember installation direction before replacement. • Remove coils. • Wrap it with wet cloth to keep its completeness for further analysis. • Desolder the 4-way valve.
<p>4. Replace it with a new one and clean the system.</p>		<ul style="list-style-type: none"> • Do use the one with the same model for replacement. The one with different model can be used after being approved by relative technicians. • Wrap it with wet cloth. • Reconnect the main body with four pipes as before. • Solder the pipelines with a soldering gun. • Do charge nitrogen during desoldering.
<p>5. Vacuum the system and recharge refrigerant.</p>		<ul style="list-style-type: none"> • Keep the vacuum degree to -1.0bar. Vacuuming period would be longer for the repaired unit. • Charged refrigerant should be the same as that stated at the nameplate.

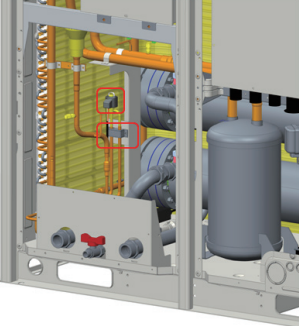
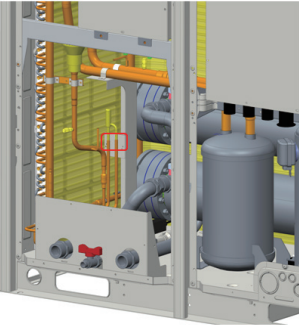
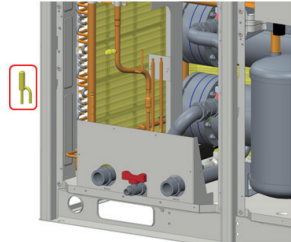

Replacement of the electric expansion valve

Note: check the whole system, pipelines and electric lines, cut off power supply and reclaim refrigerant before replacement.

Steps	Image	Instructions
<p>1. Reclaim refrigerant and remove the middle panel.</p>		<ul style="list-style-type: none"> • Cut off power supply of the unit. • Reclaim refrigerant. • Remove the middle panel.
<p>2. Take out the coils, pipe clamps and rubber pads.</p>		<ul style="list-style-type: none"> • Take out coils. • Loosen screws and take out pipe clamps and rubber pads. • Wrap the valve with wet cloth to prevent the sliding block from being burnt out. In this case, care must be taken to not let water enter the pipe.
<p>3. Desolder connection pipes.</p>		<ul style="list-style-type: none"> • Desolder connection pipes and then disconnect them with the main body of the valve. • Do charge nitrogen during desoldering. • Protection measures should be taken during soldering to prevent surrounding objects from being burnt out.
<p>4. Take out the main body.</p>		<p>Take out the main body of the electric expansion valve.</p>

Replacement of the electric expansion valve

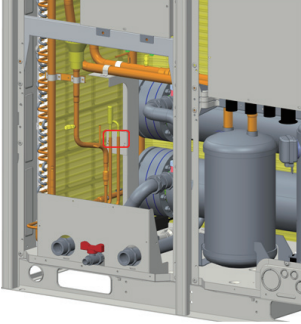
Note: check the whole system, pipelines and electric lines, cut off power supply and reclaim refrigerant before replacement.

Steps	Image	Instructions
5. Replace it with a new one.		<ul style="list-style-type: none"> • Solder pipes. • Do charge nitrogen during soldering; • Protection measures should be taken during soldering to prevent surrounding objects from being burnt out.
6. Tighten coils, pipe clamps and rubber pads; vacuum the system; recharge refrigerant and then put back the panel.		<ul style="list-style-type: none"> • The bulge of the coil should match with the re cess of the main body of the valve. • Keep the vacuum degree to -1.0bar. Vacuuming period would be longer for the repaired unit. • Charged refrigerant should be the same as that stated at the nameplate. • Power off the unit and then power it on again. • Put back the panel.



Replacement of the vapor-liquid separator

Note: properly reclaim refrigerant, prepare tools and keep good ventilation.

Steps	Image	Instructions
1. Remove front panels.		<ul style="list-style-type: none"> • Remove screws at the front panel. • Loosened screws should be put together to avoid loss. • Pull the front panel upwards and then remove it. • Properly keep the removed front panel to avoid from being damaged. • Note that there are two clasps at each panel for connecting with side panels.

Replacement of the vapor-liquid separator

Note: properly reclaim refrigerant, prepare tools and keep good ventilation.

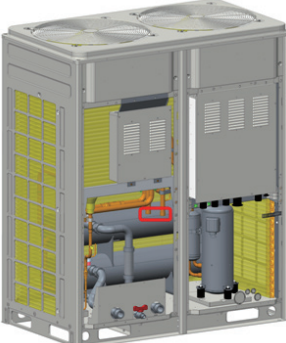
Steps	Image	Instructions
<p>2. De-solder connection pipes.</p>		<p>De-solder connection pipes with a soldering gun.</p>
<p>3. Take out the vapor-liquid separator.</p>		<p>Loosen fixed screws and take out the vapor-liquid separator.</p>
<p>4. Clean the system by charging nitrogen.</p>		<ul style="list-style-type: none"> • Connect a nitrogen line. When its size is quite large, use adhesive tape for help to keep nitrogen naturally go into the vapor-liquid separator. • Clean the system by charging nitrogen.

Replacement of the vapor-liquid separator

Note: properly reclaim refrigerant, prepare tools and keep good ventilation.

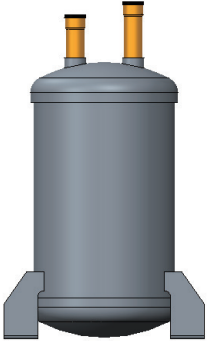
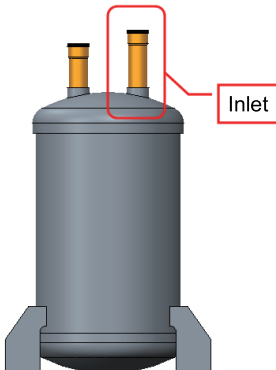
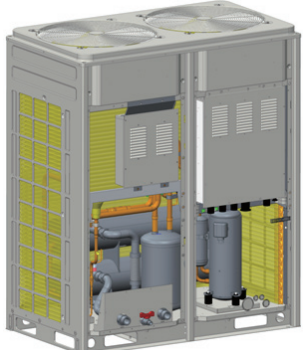
Steps	Image	Instructions
<p>5. Replace it with a new one.</p>		<p>Install the new vapor-liquid separator as per reverse steps as stated above.</p>
<p>6. When it is required to add lubricating oil, charge it from the inlet of the vapor-liquid separator before soldering.</p>		<ul style="list-style-type: none"> • Charge lubrication oil from the inlet of the vapor-liquid separator and then do soldering.
<p>7. Reconnect pipes; vacuum the system; recharge refrigerant and then put back the panel.</p>		<ul style="list-style-type: none"> • Solder pipes and do charge nitrogen during soldering. • Keep the vacuum degree to -1.0bar. Vacuuming period would be longer for the repaired unit. • Charged refrigerant should be the same as that stated at the nameplate.

(2) LSQWRF60VM/NaA-M, LSQWRF65VM/NaA-M and LSQWRF60VM/NhA-M

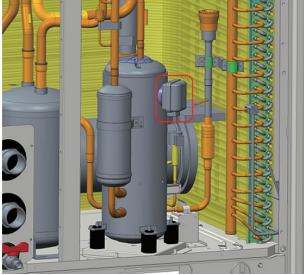
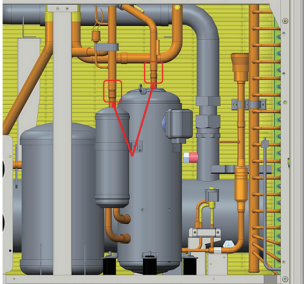
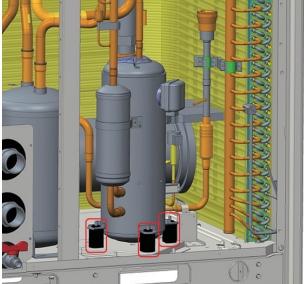

Replacement of the compressor

Note: be sure there is no refrigerant inside the system and power supply has been cut off before replacement.

Steps	Image	Instructions
<p>1. Remove the front panels.</p>		<ul style="list-style-type: none"> • Remove screws at the front panel. • Loosened screws should be put together to avoid loss. • Pull the front panel upwards and then remove it. • Properly keep the removed front panel to avoid from being damaged. • Note: there are two clasps at each panel for connecting with side panels.
<p>2. Remove power lines and the electric heater.</p>		<ul style="list-style-type: none"> • Remove the insulation of the compressor. • Loosen screws of power lines with a screwdriver. • Draw out power lines. • Draw out the electric heater. • Note: power lines and their terminals should be numbered to avoid incorrect rewiring.
<p>3. Disconnect power lines to the ompressor.</p>		<ul style="list-style-type: none"> • Desolder pipes quick to avoid deformation. • Keep the replaced compressor complete for further analysis.
<p>4. Loosen screws at feet of the compressor.</p>		<ul style="list-style-type: none"> • Loosen screws at feet of the compressor with a adjustable or box spanner. • Loosened screws should be put together to avoid loss.

Replacement of the compressor

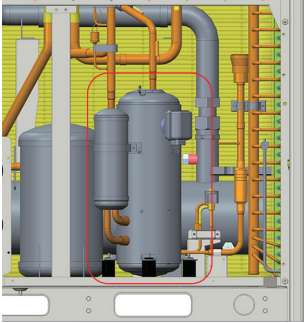
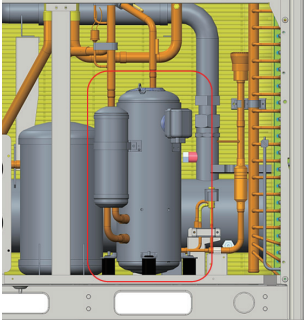
Note: be sure there is no refrigerant inside the system and power supply has been cut off before replacement.

Steps	Image	Instructions
<p>5. Replace the compressor with a new one.</p>		<ul style="list-style-type: none"> • During replacement, care must be taken to not damage rubber pads. • Seal the replaced compressor to prevent moisture entering. • Place a new compressor at the rubber pads. Steel bushing is required for rubber pads. • Tighten the steel bushing with screws.
<p>6. Reconnect the suction line, the discharge line, other pipes and electric lines. Then, check for normal operation of the compressor.</p>		<ul style="list-style-type: none"> • Reconnect and resolder the suction and discharge lines. Do charge nitrogen during soldering. • After soldering, charge high-pressure nitrogen for the leak test. • Power on the unit and start it through a AC contact for 2~3 seconds. • When the compressor runs reversely, it would generate harsh noise.
<p>7. Put back the front panels.</p>		<p>Put back front panels and tighten screws.</p>

Note: there would be trapped oil inside the compressor during replacement, which would not affect its reliability but increase resistance to the rotors and then consume more power. In order to expel it, it would be better to install another valve at the lower point of the suction line. After that, run the compressor for ten minutes and then open this valve until no oil comes out. Repeat this operation twice for a normal oil level.

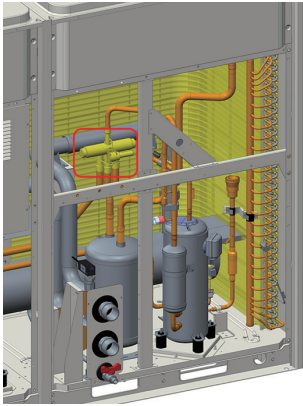
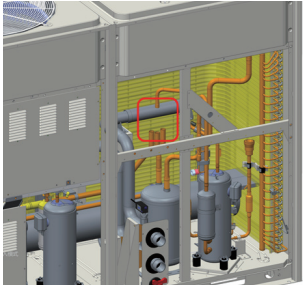
Replacement of the 4-way valve		
<p>Note: be sure there is no refrigerant inside the system and power supply has been cut off before replacement.</p>		
Steps	Image	Instructions
<p>1. Remove the front panel.</p>		<ul style="list-style-type: none"> • Remove screws at the front panel. • Loosened screws should be put together to avoid loss. • Pull the front panel upwards and then remove it. • Properly keep the removed front panel to avoid from being damaged. • Note: there are two clasps at each panel for connecting with side panels.
<p>2. Remove the electric control box.</p>		<ul style="list-style-type: none"> • Disconnect electric lines inside and outside of the electric box. • Protection measures should be taken to the internal elements to prevent them from being damaged.
<p>3. Record the direction of the 4-way valve before de-soldering. The multi-system unit cannot take other system as a example.</p>		<ul style="list-style-type: none"> • Remember installation direction before replacement. • Remove coils. • Wrap it with wet cloth to keep its complete ness for further analysis. • Desolder the 4-way valve.

Replacement of the 4-way valve

Note: be sure there is no refrigerant inside the system and power supply has been cut off before replacement.

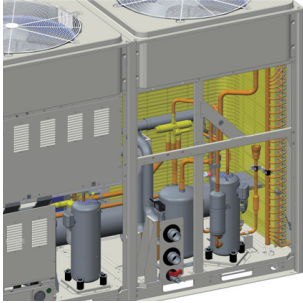
Steps	Image	Instructions
<p>4. Vacuum the system and recharge refrigerant.</p>		<ul style="list-style-type: none"> • Keep the vacuum degree to -1.0bar. • Vacuuming period would be longer for the repaired unit. • Charged refrigerant should be the same as that stated at the nameplate.

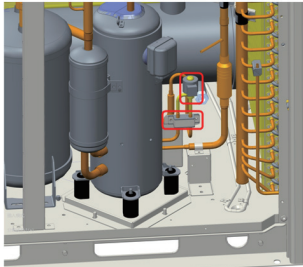
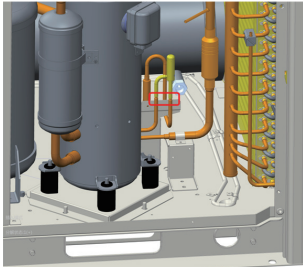

Replacement of the electric expansion valve

Note: be sure there is no refrigerant inside the system and power supply has been cut off before replacement.

Steps	Image	Instructions
<p>1. Reclaim refrigerant and remove the middle panel.</p>		<ul style="list-style-type: none"> • Cut off power supply of the unit. • Reclaim refrigerant. • Remove the middle panel.
<p>2. Take out the coils, pipe clamps and rubber pads.</p>		<ul style="list-style-type: none"> • Take out coils. • Loosen screws and take out pipe clamps and rubber pads. • Wrap the valve with wet cloth to prevent the sliding block from being burn out. In this case, care must be taken to not let water enter the pipe.
<p>3. Desolder connection pipes.</p>		<ul style="list-style-type: none"> • Desolder connection pipes and then disconnect them with the main body of the valve. • Do charge nitrogen during desoldering. • Protection measures should be taken during soldering to prevent surrounding objects from being burnt out.

Replacement of the electric expansion valve

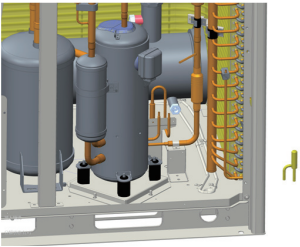
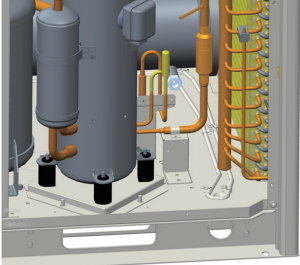
Note: be sure there is no refrigerant inside the system and power supply has been cut off before replacement.

Steps	Image	Instructions
4. Take out the main body.		<p>Take out the main body of the electric expansion valve.</p>
5. Replace it with a new one.		<ul style="list-style-type: none"> • Solder pipes. • Do charge nitrogen during soldering. • Protection measures should be taken during soldering to prevent surrounding objects from being burnt out.
6. Tighten coils, pipe clamps and rubber pads; vacuum the system; recharge refrigerant and then put back the panel.		<ul style="list-style-type: none"> • The bulge of the coil should match with the recess of the main body of the valve. • Keep the vacuum degree to -1.0bar. Vacuuming period would be longer for the repaired unit. • Charged refrigerant should be the same as that stated at the nameplate. • Power off the unit and then power it on again. • Put back the panel.

(3) LSQWRF130VM/NhA-M

Replacement of the compressor

Note: be sure there is no refrigerant inside the system and power supply has been cut off before replacement.

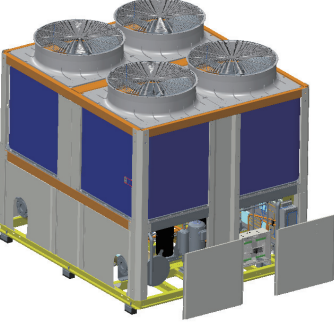
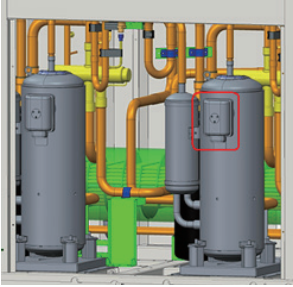
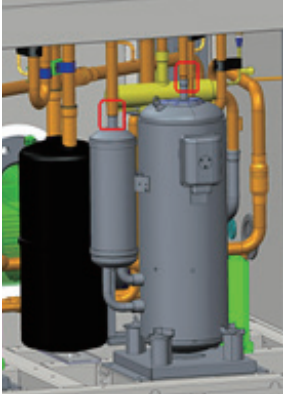
Steps	Image	Instructions
<p>1. Remove the front panels.</p>		<ul style="list-style-type: none"> • Remove screws at the front panel. • Loosened screws should be put together to avoid loss. • Pull the front panel upwards and then remove it. • Properly keep the removed front panel to avoid from being damaged.
<p>2. Remove power lines and the electric heater.</p>		<ul style="list-style-type: none"> • Loosen screws of power lines with a screwdriver. • Draw out power lines. • Draw out the electric heater. • Note that power lines and their terminals should be numbered to avoid incorrect rewiring.
<p>3. Disconnect power lines to the compressor.</p>		<ul style="list-style-type: none"> • Desolder pipes quick to avoid deformation. • Keep the replaced compressor complete for further analysis.

Replacement of the compressor

Note: be sure there is no refrigerant inside the system and power supply has been cut off before replacement.

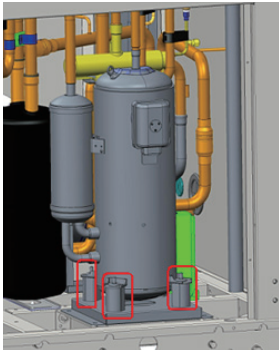
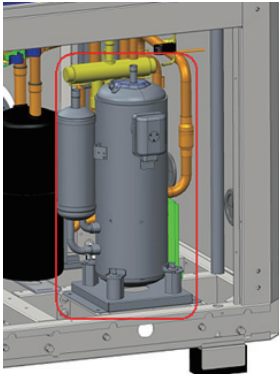
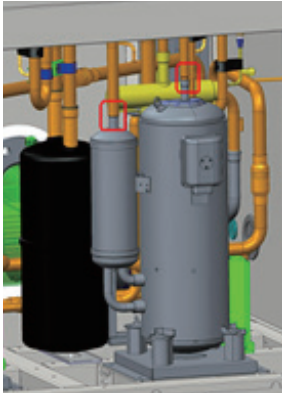
Steps	Image	Instructions
<p>4. Loosen screws at the feet of the compressor.</p>		<ul style="list-style-type: none"> • Loosen screws at feet of the compressor with a adjustable or bushing spanner. • Loosened screws should be put together to avoid loss.
<p>5. Replace the compressor with a new one.</p>		<ul style="list-style-type: none"> • During replacement, care must be taken to not damage rubber pads. • Seal the replaced compressor to prevent moisture entering; • Place a new compressor at the rubber pads. Steel bushing is required for rubber pads. • Tighten the steel bushing with screws.
<p>6. Reconnect the suction line, the discharge line, other pipes and electric lines. Then, check for normal operation of the compressor.</p>		<ul style="list-style-type: none"> • Reconnect and resolder the suction and discharge lines. Charge nitrogen during soldering. • After soldering, charge high-pressure nitrogen for the leak test. • Power on the unit and start it through an AC contact for 2 to 3 seconds. • When the compressor runs reversely, it would generate harsh noise.

Replacement of the compressor

Note: be sure there is no refrigerant inside the system and power supply has been cut off before replacement.

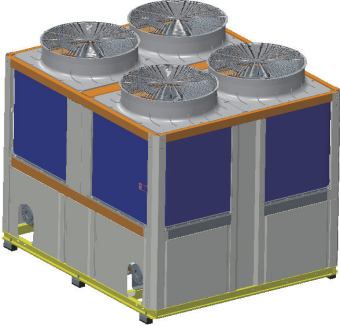
Steps	Image	Instructions
7. Put back the front panels.		Put back front panels and tighten screws.

Note: there would be trapped oil inside the compressor during replacement, which would not affect its reliability but increase resistance to the rotors and then consume more power. In order to expel it, it would be better to install another valve at the lower point of the suction line. After that, run the compressor for ten minutes and then open this valve until no oil comes out. Repeat this operation twice for normal oil level.

Replacement of the 4-way valve

Note: be sure power supply has been cut off and refrigerant has been reclaimed before replacement.

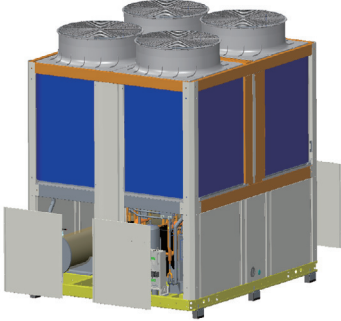
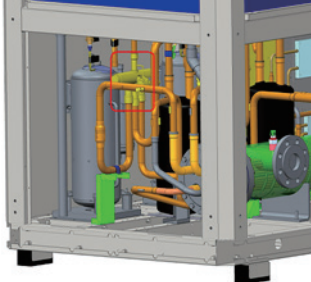
Steps	Image	Instructions
1. Remove the front panel.		<ul style="list-style-type: none"> • Remove screws at the front panel. • Loosened screws should be put together to avoid loss. • Pull the front panel upwards and then remove it. • Properly keep the removed front panel to avoid from being damaged.
2. Record the direction of 4-way valves before remove it. It is prohibited to take other units as reference when removing 4-way valves of a multi-system unit.		<ul style="list-style-type: none"> • Record the direction of a 4-way valve. • Remove its coils. • To keep it complete, wrap the valve with a wet cloth. • Desolder the valve.

Replacement of the 4-way valve

Note: be sure power supply has been cut off and refrigerant has been reclaimed before replacement.

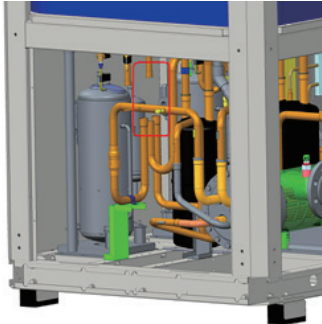
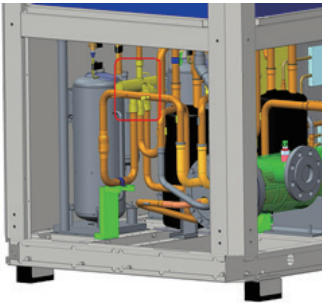
Steps	Image	Instructions
<p>3. Replace it with a new one and pipes.</p>		<ul style="list-style-type: none"> • Do not use the one with the same model for replacement. The one with a different model can be used after being approved by relative technicians. • Wrap it with wet cloth. • Reconnect the main body with four pipes as before. • Solder the pipelines with a soldering gun. • Do not charge nitrogen during desoldering.
<p>4. Vacuum the system and recharge refrigerant.</p>		<ul style="list-style-type: none"> • Keep the vacuum degree to -1.0bar. Vacuuming period would be longer for the repaired unit. • Charged refrigerant should be the same as that stated at the nameplate.

Replacement of the electric expansion valve

Note: check the whole system, pipelines and electric lines, cut off power supply and reclaim refrigerant before replacement.

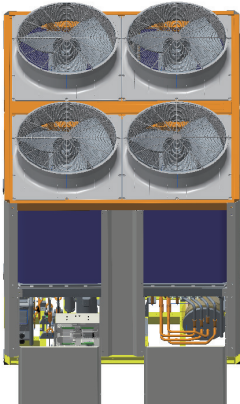
Steps	Image	Instructions
<p>1. Reclaim refrigerant and remove the middle panel.</p>		<ul style="list-style-type: none"> • Cut off power supply of the unit. • Reclaim refrigerant. • Remove the middle panel.

Replacement of the electric expansion valve

Note: check the whole system, pipelines and electric lines, cut off power supply and reclaim refrigerant before replacement.

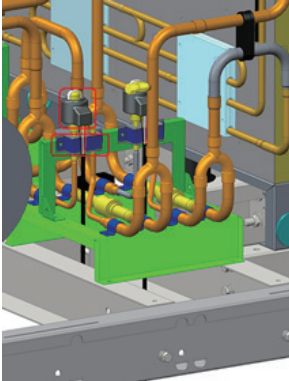
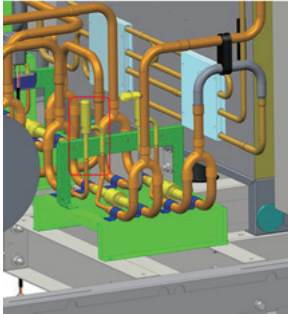
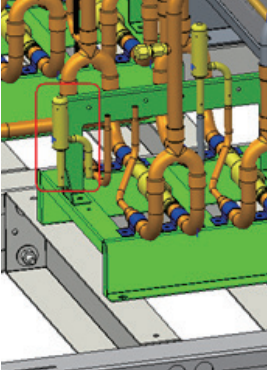
Steps	Image	Instructions
<p>2. Take out the coils, pipe clamps and rubber pads.</p>		<ul style="list-style-type: none"> • Take out coils. • Loosen screws and take out pipe clamps and rubber pads. • Wrap the valve with wet cloth to prevent the sliding block from being burnt out. In this case, care must be taken to not let water enter the pipe.
<p>3. Desolder connection pipes.</p>		<ul style="list-style-type: none"> • Desolder connection pipes and then disconnect them with the main body of the valve. • Do charge nitrogen during desoldering. • Protection measures should be taken during soldering to prevent surrounding objects from being burnt out.
<p>4. Take out the main body.</p>		<p>Take out the main body of the electric expansion valve.</p>

Replacement of the electric expansion valve

Note: check the whole system, pipelines and electric lines, cut off power supply and reclaim refrigerant before replacement.

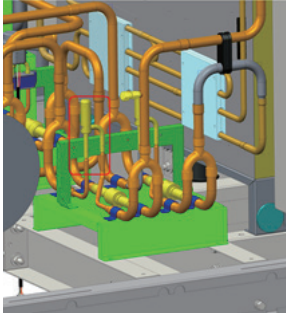
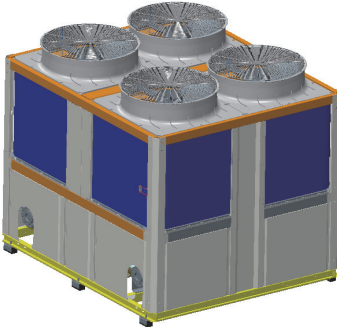
Steps	Image	Instructions
5. Replace it with a new one.		<ul style="list-style-type: none"> • Solder pipes. • Do charge nitrogen during soldering. • Protection measures should be taken during soldering to prevent surrounding objects from being burnt out.
6. Tighten coils, pipe clamps and rubber pads; vacuum the system; recharge refrigerant and then put back the panel.		<ul style="list-style-type: none"> • The bulge of the coil should match with the recess of the main body of the valve. • Keep the vacuum degree to -1.0bar. Vacuuming period would be longer for the repaired unit. • Charged refrigerant should be the same as that stated at the nameplate. • Power off the unit and then power it on again. • Put back the panel.

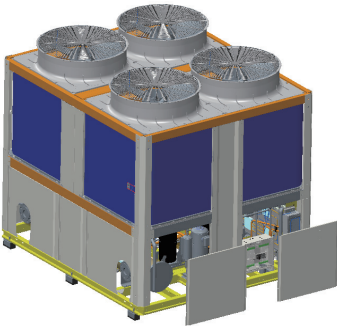

Replacement of vapor-liquid separator

Note: properly reclaim refrigerant, prepare tools and keep good ventilation.

Steps	Image	Instructions
1. Remove front panels.		<ul style="list-style-type: none"> • Remove screws at the front panel. • Loosened screws should be put together to avoid loss. • Pull the front panel upwards and then remove it. • Properly keep the removed front panel to avoid from being damaged. • Note: there are two clasps at each panel for connecting with side panels.

Replacement of vapor-liquid separator

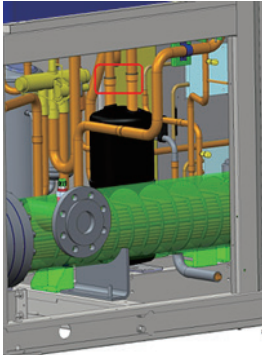
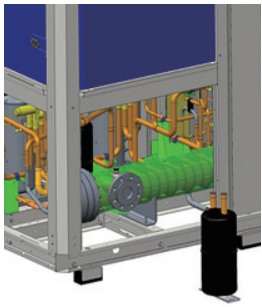
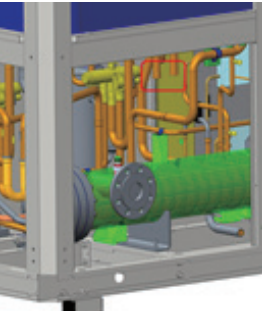
Note: properly reclaim refrigerant, prepare tools and keep good ventilation.

Steps	Image	Instructions
<p>2. De-solder connection pipes.</p>		<p>De-solder connection pipes with a soldering gun.</p>
<p>3. Take out the vapor-liquid separator.</p>		<p>Loosen fixed screws and take out the vapor-liquid separator.</p>
<p>4. Clean the system by charging nitrogen.</p>		<ul style="list-style-type: none"> • Connect a nitrogen line. When its size is quite large, you need to use adhesive tape for help to keep nitrogen naturally go into the vapor-liquid separator. • Clean the system by charging nitrogen.
<p>5. Replace it with a new one.</p>		<p>Install the new vapor-liquid separator as per reverse steps as stated above.</p>

Replacement of vapor-liquid separator

Note: properly reclaim refrigerant, prepare tools and keep good ventilation.

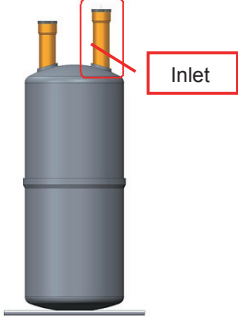
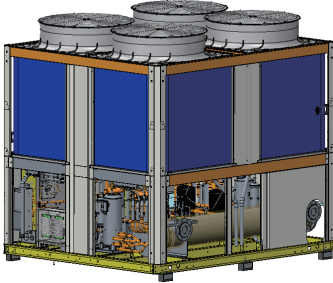
Steps	Image	Instructions
<p>6. When lubricating oil is needed, you need to charge it from the inlet of the vapor-liquid separator before soldering.</p>	 <p>The image shows a cylindrical gray vapor-liquid separator. It has two vertical pipes at the top. The right-hand pipe is highlighted with a red square and a red arrow pointing to it from a red-bordered box labeled 'Inlet'.</p>	<p>Charge lubrication oil from the inlet of the vapor-liquid separator and then do soldering.</p>
<p>7. Reconnect pipes; vacuum the system; recharge refrigerant and then put back the panel.</p>	 <p>The image is a cutaway view of a refrigeration unit. It shows a metal cabinet with blue panels. Inside, there are three large cylindrical refrigerant tanks at the top, and various pipes, valves, and electrical components are visible in the lower section.</p>	<ul style="list-style-type: none"> • Solder pipes and do charge nitrogen during soldering. • Keep the vacuum degree to -1.0bar. Vacuuming period would be longer for the repaired unit • Charged refrigerant should be the same as that stated at the nameplate.

4.5 Routine maintenance

4.5.1 Repairs to refrigerant leakage

When soapsuds often used to detect leakage of a refrigeration system is applied to possible leakage points. If there are bubbles, leaks occur and need repairs by brazing. If soapsuds does not work, an electronic leak detector is an alternative. Intake and exhaust pressures indicate refrigerant charge. If leaks exist or parts are going to be replaced, leakage test must be taken. Refrigerant charges in two following cases should be treated in different manners.

(1) Full leaks

A leak test for the system must be taken with high-pressure nitrogen (15~20 kg) or refrigerant. If brazing is needed, gases in the system must be evacuated. The system must be treated with vacuum pumping before refrigerant charges.

- 1) Connect evacuation pipes with refrigerant nozzles at low-pressure and high-pressure sides;
- 2) Vacuumize the system piping by a vacuum pump.

Procedures (one system as an example):

Step 1: Remove the high-pressure nitrogen that was used for the leak test.

Step 2: Fix pressure gauges to refrigerant nozzles of high-pressure and low-pressure valves (note: vacuum pumping should be done with both valves in the meantime.). Either of two dials must register low pressures since only its readings indicate vacuum.

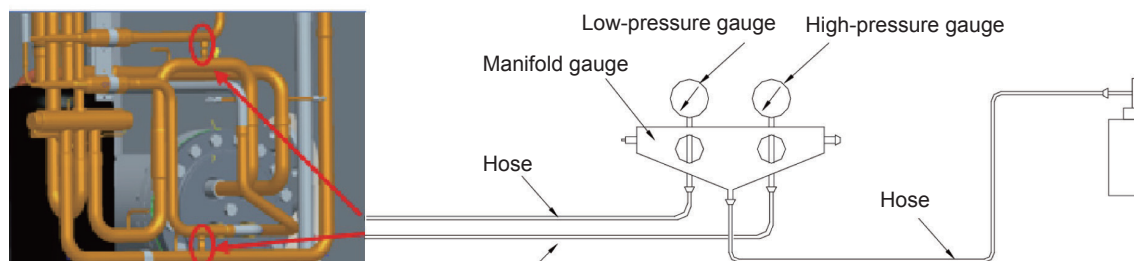

Vacuum pumping

Step 3: Turn on switches at low-pressure and high-pressure sides. Start a vacuum pump let it continues for 0.5~1.0 hour after the reading of a pressure gauge falls to -1bar.

Step 4: Close the valves connected to the vacuum pump shown in the figure above and then shut down the pump. (Notice: it must be done in this order, or gases will enter the system again.)

Step 5: Take a pressure test to make sure that the pressure of the system is no less than 80Pa and will not noticeably rebound within 1 hour.

Up to now, vacuum pumping has been finished.

3) Keep the pressure for 30 minutes, and charge refrigerant when the pressure is no more than 100Pa. Start charging according to the proper volume indicated by the nameplate and main technical parameters table.

(2) Recharge refrigerant

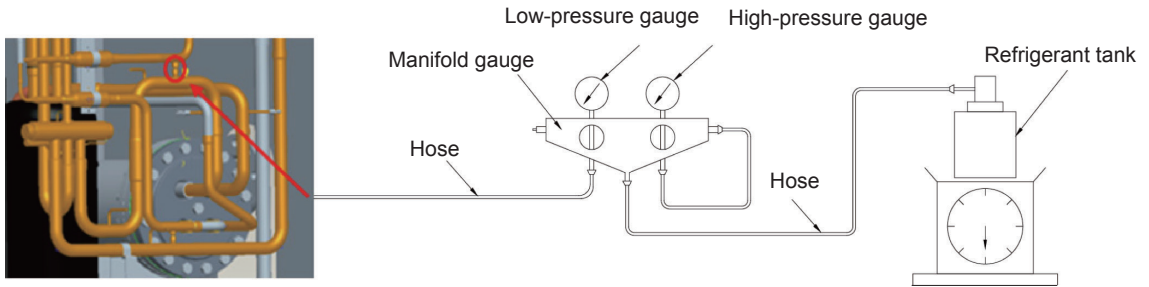

Charging process

Excessive or deficient refrigerant may cause abnormal operation, malfunction or damage to a compressor, so charge volume must comply with the requirements on the unit nameplate which have been decided in strict tests; The figure may serve as a reference; a charge process is as follows (one system as an example):

Step 1: Place a refrigerant container on an electronic scale and connect the container and the pressure gauges by a flexible tube.

Step 2: Remove gases inside the flexible tube—half turning the shut-off valve of the container, loosen the joint device between the flexible tube and pressure gauge; tighten the joint device when a sound is sent out for 5s.

Step 3: Power up and down the electronic scale to enable it to reset.

Step 4: Ensure that the flexible tube has been evacuated and the scale reset, turn on all valves connecting refrigerant containers and the unit; charge refrigerant required by the nameplate to prevent oil dilution caused by excessive charging, and inhibit a capacity decline of the unit induced by insufficient charging; when the unit is running, make sure it is gaseous refrigerant (as possible as it can be) from a refrigerant container (that cannot be turned upside down) that is injected into refrigerant nozzles on intake lines; when the unit powered down, be sure to charge refrigerant via the refrigerant nozzle at the high-pressure side (if there is no nozzle at the high-pressure side, low-pressure side is an alternative.) in case of liquid slug.

4.5.2 Air removal

When there is air trapped in the system, expel them before charging refrigerant. The whole system must be vacuumed in accordance with the steps stated below.

- (1) Connect pipes for vacuuming at both the low and high pressure sides.
- (2) Start the vacuum pump for vacuuming.
- (3) When it reaches the targeted vacuum degree, charge refrigerant into the system. See the nameplate for type and charging mount of refrigerant. Do charging from the low pressure side. A manifold gauge should be connected to both the low and high pressure sides.
- (4) Refrigerant charging would be affected by environment temperature. If refrigerant is undercharged, start the water pump to circulate chilled water and meanwhile start the unit for refrigerant adding. In this case, vapor refrigerant should be charged.

4.6 Exploded views and part lists

■LSQWRF35VM/NaA-M

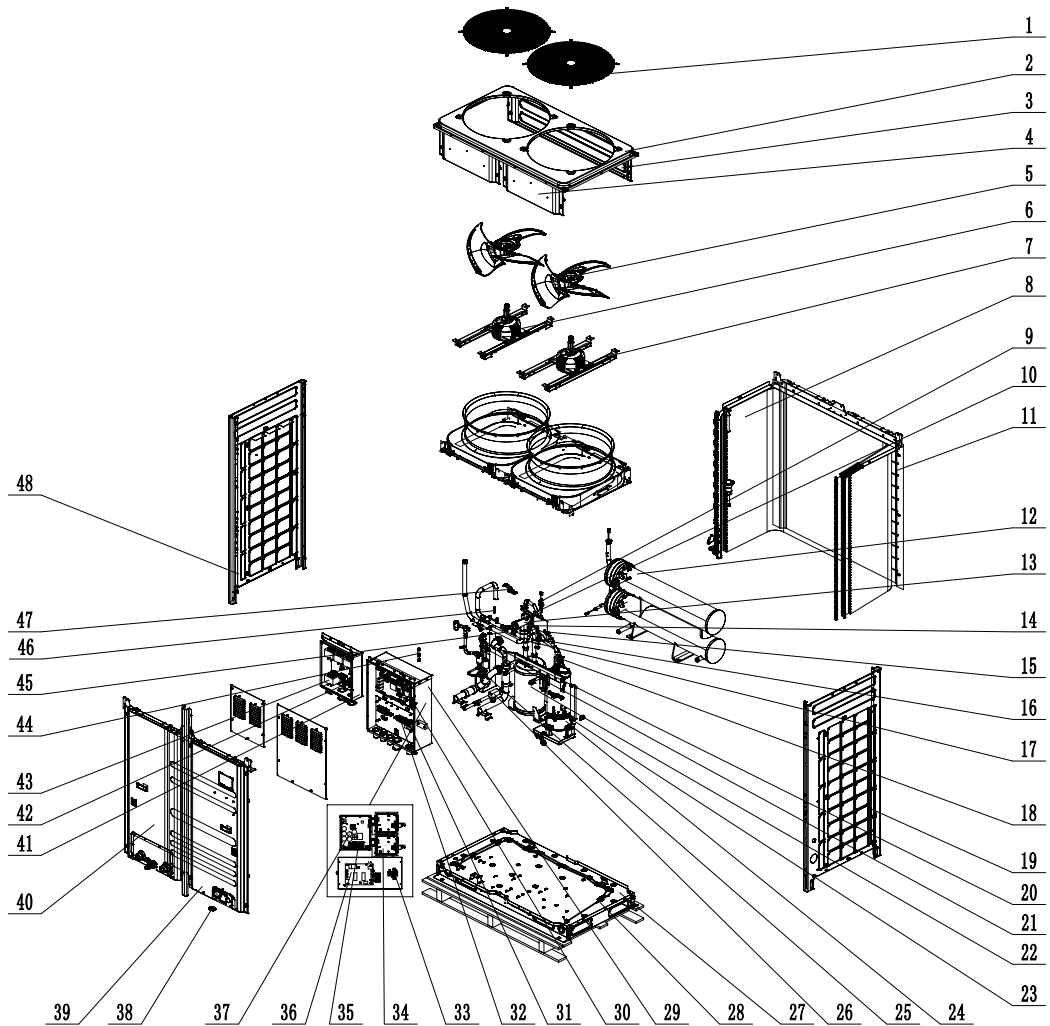

■LSQWRF35VM/NaA-M (EL01500750) part list

No.	Name	Quantity
1	Rear Grill	2
2	Coping	1
3	Top Cover (front)	2
4	Upper Cover Plate (back)	1
5	Axial Flow Fan	2
6	Brushless DC Motor	2
7	Motor Support Sub-Assy	4
8	Condenser Assy	1
9	Pressure Sensor	1
10	Magnet Coil	1
11	Rear Grill	1
12	Dry Evaporator	1
13	4-way Valve	1

Test Operation, Troubleshooting and Maintenance

No.	Name	Quantity
14	Pressure Protect Switch	1
15	Pressure Protect Switch	1
16	Pressure Protect Switch	1
17	Temp Sensor Sleeving	4
18	Temp Sensor Sleeving	1
19	Electonic expansion valve	1
20	Left Side Plate	1
21	Electric Expand Valve Fitting	1
22	Gas-liquid Separator	1
23	Electrical Heater(Compressor)	2
24	Compressor and Fittings	1
25	Strainer	2
26	Steam current Switch	1
27	Base Frame Assy	1
28	Electrical Heater (Chassis)	1
29	Electric Box Assy	1
30	Main Board	1
31	Intermediate relay	2
32	Terminal board	2
33	Phase Reverse Protector	1
34	Main Board	2
35	Rectifier bridge	1
36	Filter board	1
37	Main Board	1
38	Gland Bush	1
39	Front Panel (right)	1
40	Left Front Panel	1
41	Electric Box Assy	1
42	Terminal board	2
43	Reactor	4
44	One Way Valve	1
45	Filter	1
46	Sensor Sub-assy	1
47	Temperature Sensor Support	1
48	Right Side Plate	1

■LSQWRF60VM/NaA-M, LSQWRF65VM/NaA-M

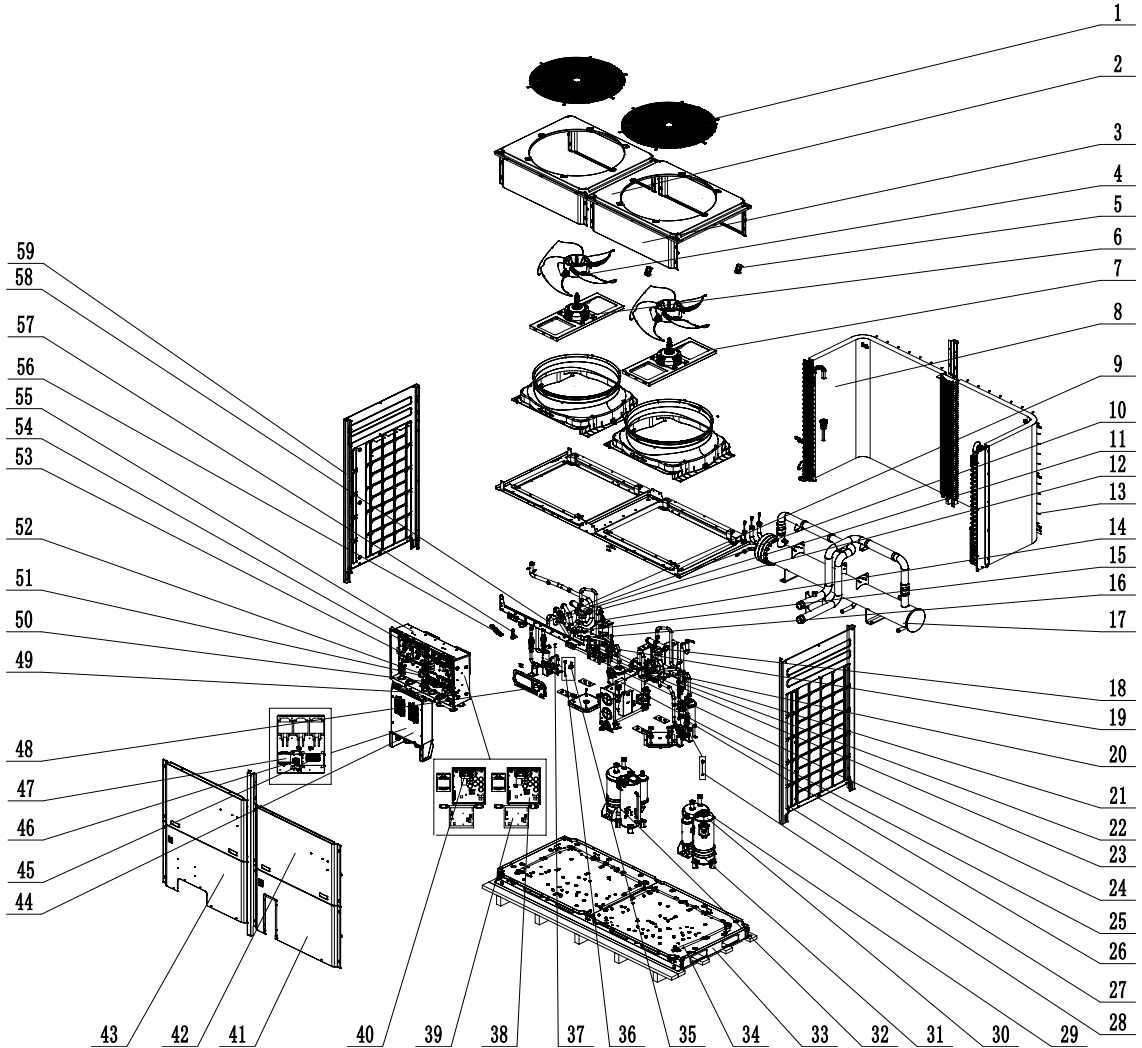

■LSQWRF60VM/NaA-M(EL01500720), LSQWRF65VM/NaA-M (EL01500760) part list

No.	Name	Quantity
1	Rear Gril	2
2	Coping	2
3	Top Cover	4
4	Axial Flow Fan	2
5	Axial Flow Fan Nesting	2
6	Brushless DC Motor	2
7	Motor Support Sub-Assy	2
8	Condenser Assy	1
9	Temp Sensor Sleevng	8
10	4-way Valve	2
11	Filte	2
12	Magnet Coil	1
13	Rear Grill 1	2

Test Operation, Troubleshooting and Maintenance

No.	Name	Quantity
14	Pressure Protect Switch	1
15	Pressure Protect Switch	1
16	Pressure Sensor	1
17	Dry Evaporator	1
18	4 Way Valve Coil	1
19	Pressure Protect Switch	1
20	Pressure Protect Switch	1
21	Pressure Protect Switch	1
22	Pressure Sensor	1
23	Pressure Protect Switch	1
24	Handle	4
25	Steam current Switch	1
26	Strainer	4
27	Right Side Plate	1
28	Electric Expand Valve Fitting	1
29	Gas-liquid Separator	2
30	Compressor and Fittings	2
31	Electrical Heater(Compressor)	2
32	Electrical Heater(Compressor)	2
33	Base Frame Assy	1
34	Electrical Heater (Chassis)	2
35	Electronic Expansion Valve	2
36	Electric Expand Valve Fitting	1
37	Temp Sensor Sleeving	2
38	Main board	2
39	Main board	2
40	Rectifier bridge	2
41	Right Front Panel	1
42	Left Front Panel	2
43	Left Front Panel	1
44	Electric Box Assy	1
45	Terminal Board	1
46	Terminal Board	1
47	Reactor	1
48	Bottom Cover Plate	1
49	Intermediate relay	2
50	Terminal Board	1
51	Phase sequence protector	1
52	Terminal Board	1
53	Filter board	2
54	Main board	1
55	Electric Box Assy	1
56	Temperature Sensor Support	1

No.	Name	Quantity
57	One Way Valve	2
58	Sensor Sub-assy	1
59	Left Side Plate	1

■LSQWRF35VM/NhA-M

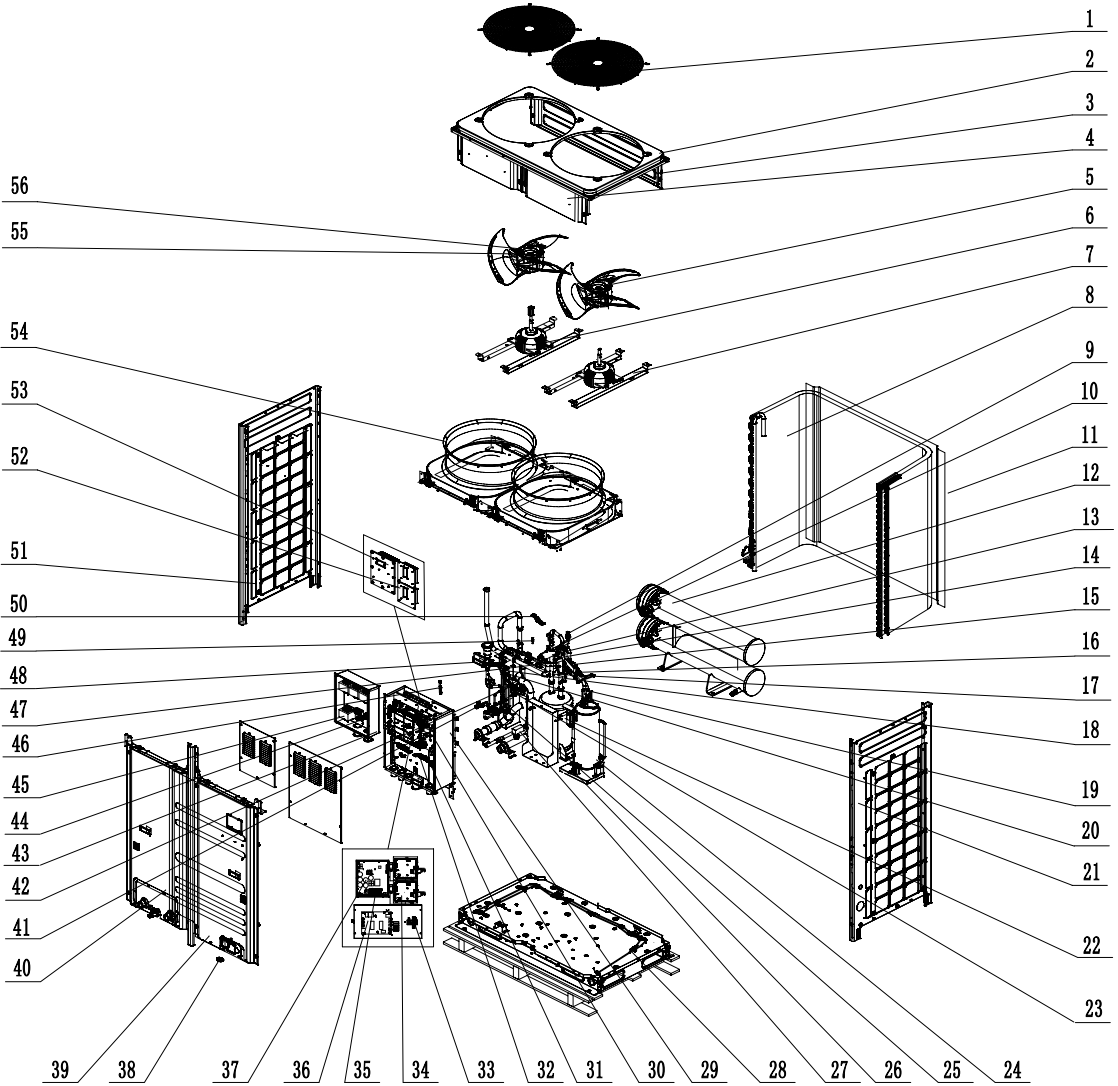

■LSQWRF35VM/NhA-M (EL01500770) part list

No.	Name of part	Quantity
1	Rear Grill	2
2	Coping	1
3	Upper Cover Plate (back)	1
4	Top Cover (front)	2
5	Axial Flow Fan	2
6	Brushless DC Motor	2
7	Motor Support Sub-Assy	4
8	Condenser Assy	1
9	Pressure Sensor	1
10	Magnet Coil	1
11	Rear Grill	1
12	Dry Evaporator	1
13	4-way Valve	1
14	Pressure Protect Switch	1
15	Pressure Protect Switch	1
16	Pressure Protect Switch	1
17	Temp Sensor Sleeving	4
18	Electric Expand Valve Fitting	1
19	Temp Sensor Sleeving	1
20	Electronic Expansion Valve	1
21	Left Side Plate	1
22	Gas-liquid Separator	1
23	Plastic Ring Of The Liquid Separator Line	1
24	Compressor and Fittings	1
25	Strainer	2
26	Conduit	2
27	Water Flow Switch	1
28	Electric Heater Strip	1
29	Electric Box Assy	1
30	Main Board	1
31	Intermediate relay	2
32	Terminal board	2
33	Phase Reverse Protector	1
34	Main Board	2
35	Rectifier bridge	1
36	Filter board	1
37	Main Board	1
38	Gland Bush	1
39	Front Panel (right)	1
40	Left Front Panel	1
41	Shut-off Valve	2
42	Solenoid Valve	1

Test Operation, Troubleshooting and Maintenance

No.	Name of part	Quantity
43	Electric Box Assy	1
44	Terminal board	1
45	Reactor	4
46	One Way Valve	1
47	Filter	1
48	Handle	2
49	Sensor Sub-assy	1
50	Temperature Sensor Support	1
51	Right Side Plate	1
52	Radiator	2
53	Radiator	1
54	Ring For Flow Diversion	2
55	Nesting Of The Axial Flow Fan	2
56	Axial Flow Fan Assy	2

■LSQWRF60M/NhA-M

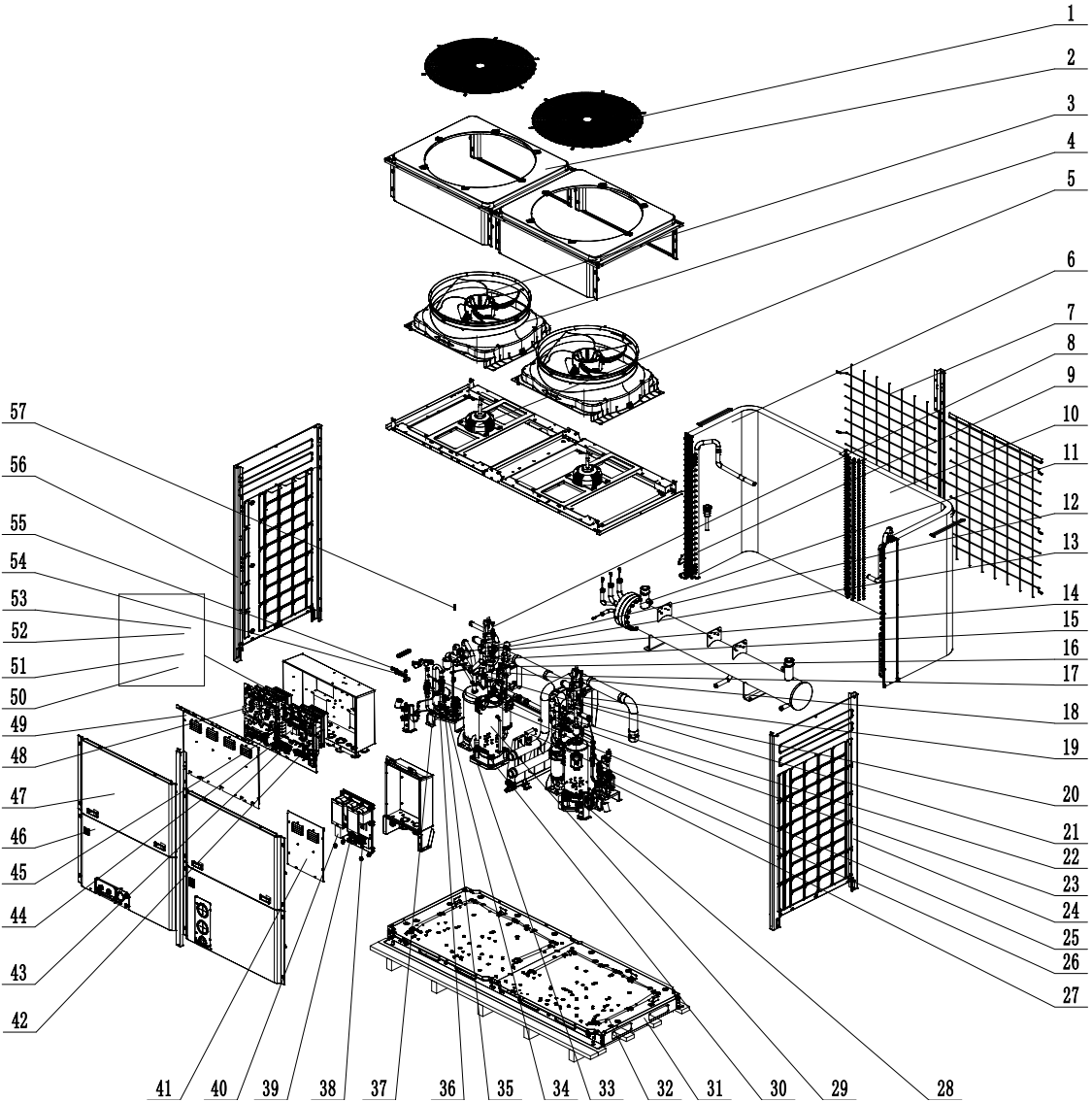

■LSQWRF60VM/NhA-M (EL01500830) part list

No.	Name of part	Quantity
1	Rear Grill	2
2	Coping	2
3	Axial Flow Fan	2
4	Ring For Flow Diversion	2
5	Brushless DC Motor	2
6	Condenser Assy (Left)	1
7	Rear Grill 1	2
8	Pressure Sensor	1
9	Temp Sensor Sleeveing	8
10	Condenser Assy (Right)	1
11	Chiller barrel	1

Test Operation, Troubleshooting and Maintenance

No.	Name of part	Quantity
12	Filter	2
13	4-way Valve	2
14	Magnet Coil	1
15	Pressure Protect Switch	1
16	Pressure Protect Switch	1
17	Pressure Sensor	1
18	Pressure Protect Switch	1
19	4-way Valve Fitting	1
20	Pressure Protect Switch	1
21	Temp Sensor Sleeving	2
22	Pressure Protect Switch	1
23	Pressure Protect Switch	1
24	Right Side Plate	1
25	Filter	4
26	Water Flow Switch	1
27	Electric Expand Valve Fitting	1
28	Electrical Heater (Compressor)	2
29	Gas-liquid Separator	2
30	Electrical Heater (Compressor)	2
31	Base Frame Assy	1
32	Electrical Heater (Chassis)	2
33	Compressor and Fittings	2
34	Solenoid valve	2
35	Solenoid valve Fitting	2
36	Electronic expansion valve	2
37	Electric Expand Valve Fitting	1
38	Terminal board	1
39	Terminal board	1
40	Reactor	1
41	Electric Box Assembly	1
42	Terminal board	1
43	Terminal board	1
44	Main Board	1
45	Phase Reverse Protector	1
46	Left Front Panel	1
47	Left Front Panel	2
48	Filter board	2
49	Electric Box Assy	1
50	Main Board	2
51	Main Board	2
52	Rectifier bridge	2
53	Radiator	2
54	Temperature Sensor Support	1

No.	Name of part	Quantity
55	One Way Valve	2
56	Left Side Plate	1
57	Sensor Sub-assy	1

■LSQWRF130M/NhA-M

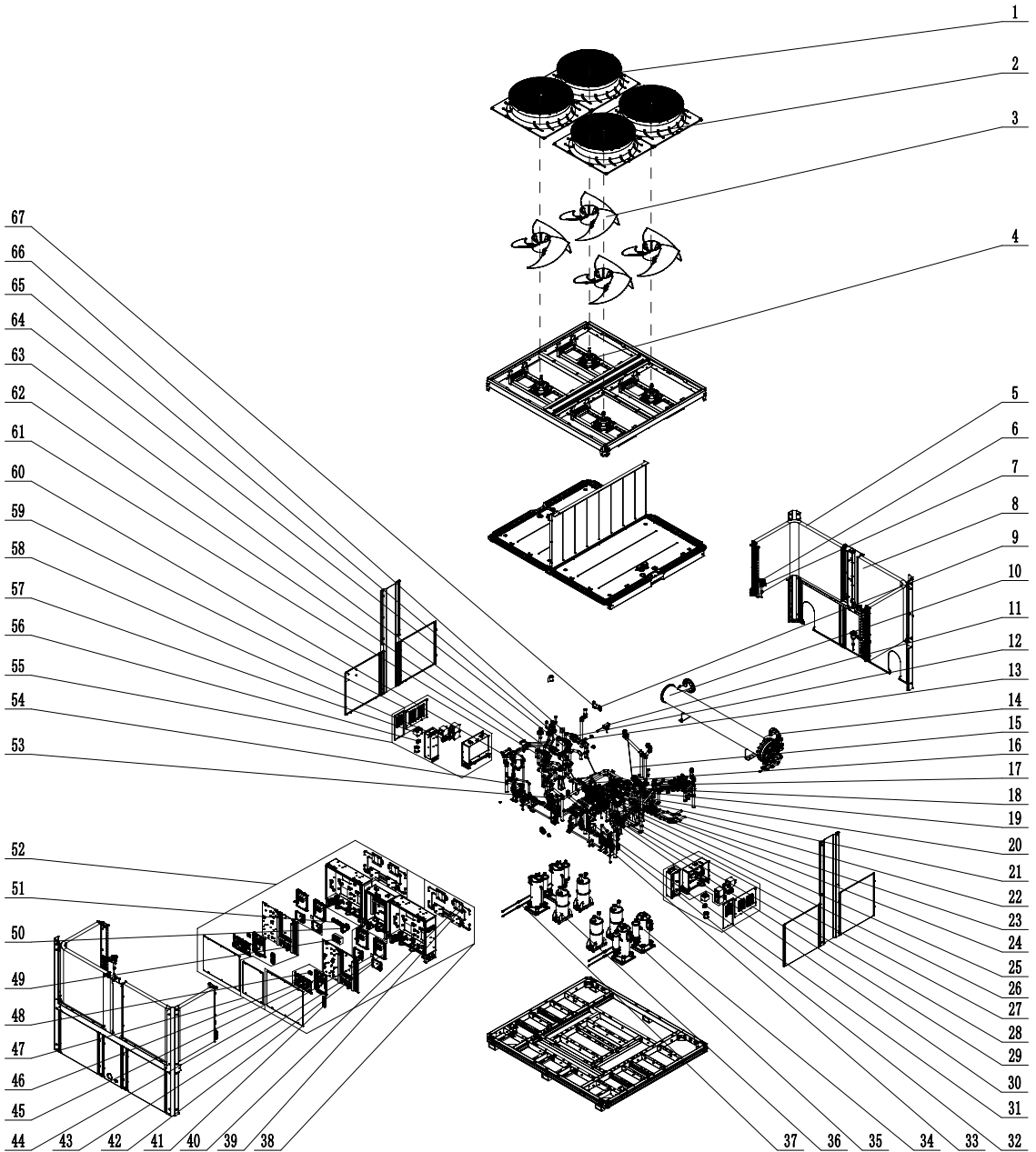

■LSQWRF130M/NhA-M (EL01500970) part list

No.	Name of parts	Quantity
1	Rear Grill	4
2	Streamlined Dome	4
3	Axial Flow Fan	4

Test Operation, Troubleshooting and Maintenance

No.	Name of parts	Quantity
4	Brushless DC Motor	4
5	Condenser Assy	2
6	One Way Valve	4
7	Temp Sensor Sleeving	16
8	Rear Panel	2
9	Temperature Sensor Support	2
10	Dry Evaporator	1
11	Steam current Switch	1
12	Pressure Protect Switch	1
13	Pressure Protect Switch	2
14	Temperature Probe	3
15	Pressure Sensor	1
16	Electromagnetic Valve	4
17	Electric Expand Valve Fitting	1
18	Pressure Protect Switch	2
19	Magnet Coil	1
20	Electronic Expansion Valve	4
21	4-Way Valve	4
22	Pressure Protect Switch	1
23	Temp Sensor Sleeving	4
24	Bidirection Strainer	8
25	Magnet Coil	2
26	Pressure Protect Switch	1
27	One Way Valve	8
28	Electric Expand Valve Fitting	1
29	Electric Expand Valve Fitting	1
30	Electric Expand Valve Fitting	1
31	Electric Expand Valve Fitting	1
32	Electronic Expansion Valve	4
33	Electric Expand Valve Fitting	1
34	Compressor and Fittings	4
35	Electrical Heater	4
36	Gas-liquid Separator	4
37	Electrical Heater	4
38	Electric Cabinet Sub-Assy	1
39	Radiator	4
40	Radiator	4
41	Terminal Board	5
42	Main Board	4
43	Drive Board	4
44	Main Board	2
45	Main Board	2
46	Filter Board	4

Test Operation, Troubleshooting and Maintenance

No.	Name of parts	Quantity
47	Electric Box Assy	1
48	Terminal Board	2
49	Terminal Board	1
50	Phase Reverse Protector	1
51	Terminal Board	1
52	Electric Box Assy	1
53	Electric Expand Valve Fitting	1
54	Electric Expand Valve Fitting	1
55	Electric Cabinet Assy	2
56	Terminal Board	2
57	Reactor	2
58	Terminal Board	2
59	Electric Cabinet Assy	2
60	Cut-off valve 1/4(N)	8
61	Pressure Sensor	2
62	Pressure Protect Switch	2
63	Pressure Protect Switch	1
64	Pressure Sensor	1
65	Pressure Protect Switch	2
66	Magnet Coil	1
67	Sensor Support	2

4.7 Maintenance

4.7.1 Requirements for maintenance

The unit has undergone a series of strict tests prior to delivery to ensure qualified performance, however, in order to keep reliable performance and extend its service life, the unit should be maintained routinely and periodically by the qualified service personnel.

Routine maintenance items
Is there any unusual noise and vibration?
Is there any unusual noise and vibration for the compressor in operation? Is there any unusual smell?
Do the operating pressure, voltage and current keep normal? If not, figure out the cause and then eliminate it?
Are all temperature sensors and pressure transducers installed securely?

Periodic maintenance items
Is any wiring loosened and insulated securely?
Does any electric element work reliably? If not, change it timely?
Does any throttling valve and control valve leaks? Can any valve be opened or closed flexibly? Is any filter clogged?
Is the temperature setpoint proper?
Is there a large amount of condensate at the chilled water pipe or the condensate pipe? Is insulation layer damaged?

◆ Requirements on water quality and cleaning

Industrial water used as chilled water produces little scale, but well or river water will bring much scale, sand and other sediment which then would block up the chilled water flow and make the evaporator frozen up. Therefore, it is necessary to filter or chemically soften water before it flows into the water system and also take analysis to quality. Once it is found water quality is dissatisfactory, and then only industrial water is available.

Water quality requirement						
Items			Cold/hot water		Trend	
			Circulating water	Makeup water	Corrosion	Scalelike sediment
Basic items	pH (25°C)		6.8-8.0	6.8-8.0	○	○
	Electrical conductivity (25°C)	μs/cm	<400	<300	○	○
	Cl ⁻	mg (Cl ⁻)/L	<50	<50	○	
	SO ₄ ²⁻	mg (SO ₄ ²⁻)/L	<50	<50	○	
	Acid consumption (pH4.8)	mg (CaCO ₃) /L	<50	<50		○
	Total hardness	mg (CaCO ₃) /L	<70	<70		○
Other items	Fe	mg (Fe) /L	<1.0	<0.3	○	○
	S ²⁻	mg (S ²⁻) /L	Undetectable	Undetectable	○	
	NH ⁴⁺	mg (NH ⁴⁺)/L	<1.0	<0.3	○	
	SiO ²	mg (SiO ₂)/L	<30	<30		○

NOTE: "○" indicates possible corrosion or scaling.

Even though water quality is under strict control, calcium oxide or other minerals will gradually accumulate on the surface of the evaporator. Then, it will reduce the heat exchange efficiency of the evaporator and consequently lead to poor performance of the unit.

Therefore, the pipe system should be cleaned periodically. Oxalic acid, acetic acid and formic acid can be used as the organic cleaning agent, but the strong chloracid is not allowed as it will corrode the copper tube of the heat exchanger and then lead to water and refrigerant leakage.

(1) Preparation of materials and tools

Several bags of environmental friendly scale remover, or similar cleaning liquid.

(2) Cleaning instructions

- 1) Estimate the required amount of scale remover in accordance with the system water volume and severity of scailing.
- 2) Add the scale remover to the water tank and the scale remover.
- 3) Start through the contact the water pump every 10 minutes and spread the scale remover in water more quickly and widely.
- 4) After that, follow the steps below.
 - Let the water pump run for another 1-2 hour(s).
 - 1-2 hours later, change the cleaning solution to anti-rusting agent. Then, drain the water system and check the water quality. If water is cloudy, then it indicates the cleaning effect is satisfactory.
 - Open the water inlet to see if scale on the shell and tube has been removed. If not, clean the shell and tube separately again by the skilled serviceman and then rinse them. If there is still sand, scale and other foreign matters at the bottom of the shell and tube, let cleaning solution in from the inlet pipe and then let the foul water out through the drain outlet.
 - Fully charge the water system and let it run for another 1-2 hour(s).
 - Stop the unit to drain up waste solution. If impossible, drain it with making up water at the same time until all waster solution has been drained out completely (at this time water is transparent and PH is 7).
 - Repeat steps last two steps above.
 - Clean or change the filters in the water system.
 - See if the difference between the entering and leaving water temperature is improved.

 NOTE

- Although the cleaning agent is innocuous, but care also should be taken not to let it spill into eyes.
- The serviceman with injuries on the hand is not allowed to take this task.

Before and after cleaning, observe the running status of the unit, summarize the cleaning effect and record the running parameters.

◆ Cleaning of the finned heat exchanger

In order to keep fins work efficiently, be sure there are no leaves, cotton wool, insects, and other contaminants on the outer layer of fins, or they would lead to more energy consumption and high discharge pressure. Generally, fins should be cleaned after the unit has run for 6-12 months, or more frequently when the environment is polluted more seriously.

- (1) Cut off the power supply.
- (2) Clean with high-pressure air fins against the direction of the inlet air, or clean with high-pressure water fins at the direction upright with that of the fins but care must be taken to control the water pressure to prevent the fins from being pulled down and protect each electric element. If fins stick with oily matters, clean fins with neutral detergent solution.
- (3) The vacuum cleaner and nylon brush also can be used to remove dust and foreign matters on the surface of the heat exchanger.

4.7.2 Freeze protection in winter

When the unit is not going to be used for a long time, clean and dry the internal and external surfaces of the unit, and then it would be better to wrap it. Under the subzero climate, the unused unit should be drained completely so that the shell-and-tube evaporator would not be frozen up. Instead, the other way is adding some antifreeze into water to keep the water temperature no less than 0°C.

See the following steps for how to drain water out.

- (1) Loosen screws on the front panel and then remove the front panel
- (2) Draw out the blind plug counter clockwise to let the chilled water flow out freely until no water stays in. After that, place the blind plug back. (Note: put the container for foul water beneath the drain pipe to prevent foul water from polluting the site).

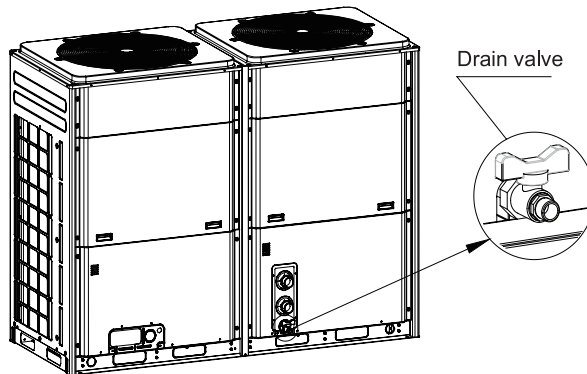



GREE ELECTRIC APPLIANCES, INC. OF ZHUHAI

Add: West Jinji Rd, Qianshan, Zhuhai, Guangdong, China, 519070

Tel: (+86-756) 8522218

Fax: (+86-756) 8669426

E-mail: global@cn.gree.com www.gree.com

For continuous improvement in the products, Gree reserves the right to modify the product specification and appearance in this manual without notice and without incurring any obligation.

JF00304157